

Installation and Maintenance Manual

Models:

UV-1, UV-250,
UV-700, UV-1200, UV-1500,
UV-3000, UV-5000 and UV-6000



 **Wyckomar**

UV Purification Systems



CAUTION - WARNING

The ballast and all electrical connections **MUST** be mounted and installed **ABOVE** the water lines to prevent the possibility of electrical shock in case of a water leak.

See "Safety Precautions" on Page 4

Please read this entire User Manual before attempting to install your UV system.

Read and follow ALL safety precautions

Keep this manual in a safe place for future reference.

Unit Serial Number: _____

Date of Purchase: _____

Please keep your sales receipt as proof of purchase for warranty purposes.

Copyright

Copyright by Wyckomar Inc. 2013. No part of this manual may be reproduced or transmitted in any form without the expressed, written permission of Wyckomar Inc.

Notice

Although Wyckomar has attempted to ensure the accuracy of the content of this manual, it is possible that this document may contain technical inaccuracies, typographical, or other errors. Wyckomar assumes no liability for any error in this publication, and for damages, whether direct, indirect, incidental, consequential or otherwise

Wyckomar provides this publication "as is" without warranty of any kind, either expressed or implied. Use of the system is at the discretion of the buyer.

The published information in this manual is subject to change without notice. Wyckomar reserves the right to make changes in the product design and layout without notification to its customers.

UV Purification Systems



Introduction

Congratulations on purchasing a Wyckomar UV purification system. Please read through the installation procedures and follow all safety warnings when setting up your system. Wyckomar Inc. manufactures several sizes of UV purification systems; however, they all operate on the same principle. Basic installation is the same for most units. Refer to the exploded view diagrams for replacement parts.

Table of Contents	Page
Section 1 - Introduction	
How Ultraviolet Water Purification Works	2
How Your Wyckomar UV Water Purifier Works	3
Section 2 - Setting Up	
Safety Precautions	4
Important Considerations	5
Installation Diagrams	6
Installation	7
Start Up Operation	8
Section 3 - Maintenance	
Disinfecting Your Water System	9
Ultraviolet Lamp Replacement	10
Quartz Dome or Sleeve Replacement / Cleaning	11
Changing Filter Cartridges	12
Filter Maintenance and Troubleshooting	13
Troubleshooting Guide	22
Section 4 - Technical Info	
Exploded Diagrams and Parts Lists	14 - 21
Section 5 - Accessories	
Filter Sets and Cartridges	23
UV Monitoring System	24
Remote Output and Operation Logging	25
Purge Valve, Hour Meter	26
Section 6 - Contact and Warranty	
Wyckomar Contact Info	27
Warranty Registration Card	28

UV Purification Systems



Introduction

How Ultraviolet Water Purification Works

Wyckomar Ultraviolet (UV) Purifiers utilize the proven principle of ultraviolet light radiation to eliminate or reduce unacceptable levels of microorganisms in water and other liquids. Ultraviolet light energy destroys bacteria, viruses, fungi, spores, algae and other such contaminants, which are pathogenic to humans, animals and plants.

Ultraviolet purification is a completely natural, non-chemical, environmentally safe technique, which adds nothing to, and removes nothing from the water (such as trace minerals).

Factors Affecting UV Purification

The Wyckomar UV Purifier is guaranteed to eliminate microbiological contamination only if the physical qualities of the influent water supply are as follows:

Turbidity (Suspended Solids): Turbidity must be < 1.0 NTU at the time of disinfection. There must be a 5-micron or less sediment prefiltration system installed before the UV system.

TDS (Total Dissolved Solids): Should not exceed approximately 500 ppm.

Total Hardness (Sum of Calcium & Magnesium): Must be < 10 gpg (grains per gallon) of hardness, otherwise pretreatment is required.

Tannins & Colour: Must be < 2.0 ppm, or pretreatment is required.

Iron: Must be < 0.3 ppm.

Manganese: Must be < 0.05 ppm.

If your water quality parameters do not meet these criteria, please contact the manufacturer for pretreatment recommendations.

UV Purification Systems



Introduction

How Your Wyckomar UV Water Purifier Works

Untreated water enters the lower portion of the purification chamber and flows through the unit in an upward circular path. The spiraling movement assures the maximum irradiation of the fluid and helps prevent larger particles from blocking the treatment of microorganisms. The purification chamber contains the ultra-violet light-producing lamp. In operation, the lamp emits a bluish glow, which is visible in the view port window on the side of some units. **WARNING: DO NOT LOOK AT THE UV LIGHT DIRECTLY.** Looking through the view port is safe, since the glass disc in the view port filters out the UV rays. On systems equipped with a UV monitor, do not look at the UV light through the view port, as the quartz disc that is used in this case does not filter out the UV rays.

If your unit does not have a view port, operation of the UV light is confirmed by a green LED indicator lamp on the ballast. As long as the appropriate indicators are glowing, the unit is working properly. An alarm will sound when the UV lamp is not functioning. When the alarm is sounding, the lamp must be replaced for the unit to operate properly. The alarm sounds also when the ballast is damaged for any reason (e.g. from moisture buildup inside, or from having received a power spike or lightning strike).

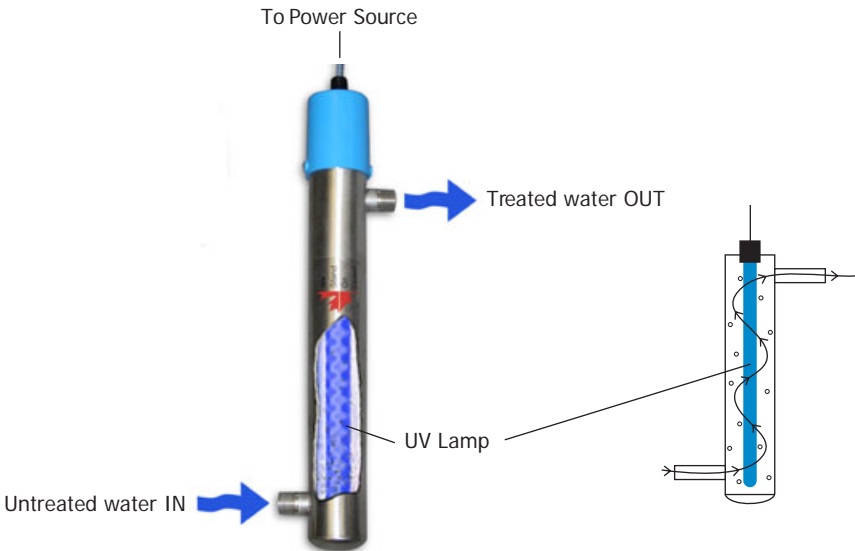

UV Purification Systems



Setting Up

Safety Precautions

Please READ and FOLLOW all safety precautions. SAVE these instructions.

Never expose your eyes directly to UV light.

This UV system is designed for indoor use only. Do not use this UV system where it may be exposed to the elements. Protect the unit from freezing at all times.

ELECTRICAL SHOCK HAZARD

This UV system is installed near water. Please take all necessary precautions. Other than where noted in this manual, **DO NOT** attempt to repair parts yourself, but contact the manufacturer or authorized dealer for repair service.

The electronic ballast in this system can get damaged from voltage and/or frequency deviations, caused by power outages or lightning strikes. Only connect this UV system to a properly grounded outlet. A GFCI circuit is recommended. It should not be plugged into the same circuit as a water pump, since the on/off cycle of the pump can cause voltage spikes in the line.

It is highly recommended, especially in rural areas, to install **a quality voltage regulator or surge suppressor, rated at > 3600 Joules** at the power input to the ballast.

In older homes, the installation of plastic water treatment devices such as filter housings may interrupt the water pipe's electrical continuity to ground. This can lead to pinhole leaking due to electrolysis or stray current corrosion. For prevention, the piping has to be properly bonded and grounded. Contact a professional plumber for information.

Ensure installation is in compliance with all local laws, regulations and codes.

DO NOT operate the UV system if the power cord, plug or any electrical component appears to be damaged or if the unit has been dropped or damaged in any way. Inspect the UV system after installation, and carefully check for leaks. **DO NOT** plug in the system if there is water on any part(s) that are not intended to be wet.

This system is to be used **ONLY** for its intended use of potable water disinfection. **DO NOT** use attachments that are not approved by the manufacturer, as this may cause problems with the UV system.

UV Purification Systems



Setting Up

Important Considerations

Wyckomar purifiers are installed either at the main water supply line or at point of use. In some installations, particularly where plumbing is old, the water may become re-contaminated in the pipes between the purifier and the faucet. Be sure to follow instructions under “Disinfecting Your Water System” on Page 9

Wyckomar purifiers are designed to be installed vertically and work best when mounted in this position. However, in cases with space restrictions, the unit may be mounted horizontally (see Installation Diagrams on Page 6).

Important: Clearance to the side or above the unit for lamp exchanges should be equal to the length of the purifier.

Caution: The ballast and all electrical connections must be mounted and installed above water lines to prevent the possibility of electric shock in the case of a water leak. A grounded electrical outlet is required (GFCI is preferred).

The manufacturer’s warranty is only applicable when prefiltered water is used. Prefilters (to 5 micron) remove sediment particles that can reduce the effectiveness of the UV lamp or potentially damage the unit.

If a water softener, iron removal system or other treatment device is installed or planned for, your purifier should be located closest to the faucet.

Install your Wyckomar purifier indoors in a protected area. The temperature should not fall below 4 °C (40 °F). Avoid conditions with high humidity to prevent condensation on the purification chamber. Ideal temperature conditions range from 9 °C to 29 °C.

Use Teflon tape (T-tape) liberally on all pipe connections (3 turns around the fitting). Do not use any other sealants other than food grade pipe dope.

Use food-grade silicon or plumber’s grease on O-rings. DO NOT use oil-based products.

UV Purification Systems



Setting Up

Installation Diagrams

Wyckomar systems can be installed vertical or horizontal. Refer to these schematic drawings for typical position of components. Ensure that there is adequate clearance at the lamp end of the unit in order to safely remove the UV lamp from the chamber. Space required for clearance is at least the length of the UV chamber.

Vertical Installation (Recommended)

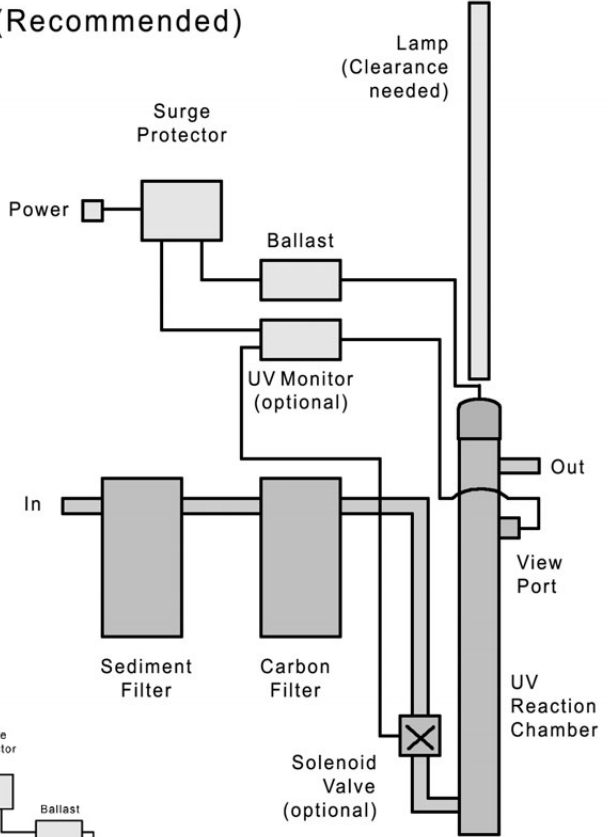

Horizontal Installation

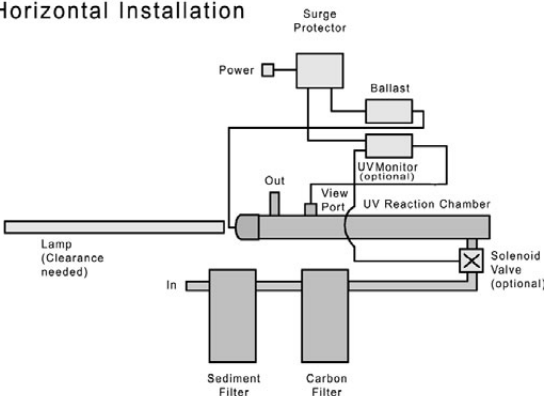

UV Purification Systems



Setting Up

Installation

Carefully select the location for the UV system and any related components. Note the direction of water flow in the supply line to which the unit is being connected.

Refer to the appropriate exploded view diagram for your unit and check to see that you have all the necessary fittings.

Parts List: 4 screws 1 quartz dome or sleeve, 1 or 2 O-rings
 1 alcohol wipe 1 Allen key wrench
 1 UV lamp w/ O-rings on each end

Turn off the main water supply valve. Fasten unit to wall, using the mounting clips ("pipe hangers") and screws provided. Press the UV chamber into the clips for a secure hold.

Install new plumbing, making sure the In and Out ports on the filter set point in the direction of water flow. Installation of bypass and valves is recommended.



Install filter set



Install UV unit

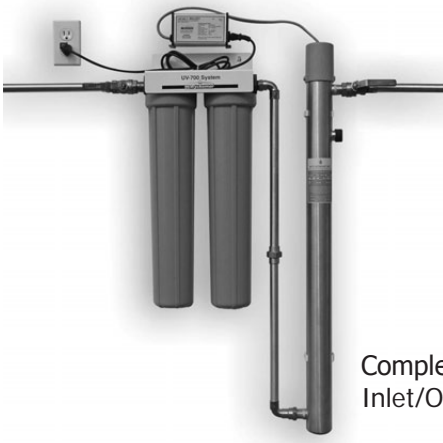

After installation of the plumbing is complete, install electrical components (surge suppressor and ballast, monitor if present) ABOVE the water line.

Complete installation with pre-filter set and UV. Inlet/Outlet shutoff valves are recommended.

UV Purification Systems



Setting Up

Installation and Start Up Operation

Take the plastic cap off the unit and remove the black nut from the end of the unit. Remove quartz sleeve/dome from packaging, being careful not to lose the spring inside the dome. You may wish to lubricate o-ring with food-grade silicon or plumber's grease (do NOT use oil based products such as Vaseline) and roll it over both ends of the sleeve or the open end of the dome. Avoid fingerprints on the sleeve/dome, wipe with alcohol.

Gently slide the sleeve/dome into the unit. For domed systems (UV-1, UV-250, UV-700 and UV-1200), the dome will center itself inside the bottom of the reaction chamber. For sleeved systems (UV-1500, UV-3000, UV-5000 and UV-6000), the sleeve(s) will protrude out of the reaction chamber at the bottom end, hold in place with hand or foot.

Thread on the compression nut(s). The O-ring will set itself into the beveled seal of the bushing on the reaction chamber. **Hand tighten** the nut(s) (do NOT use tools). In sleeved systems, install the lower plastic cap and gently tighten the set screws with the Allen key supplied. This will keep the lamp from sliding through.

Insert the UV lamp, it will center itself in the spring inside the dome in domed systems, or stop at the lower plastic cap in sleeved systems. Connect the white 4-pin electrical connector. Replace the top plastic cap and gently tighten setscrews. Unit is now ready to be turned on.

Open main water valve **slowly**. As water fills into the filter set, press the red button on top of the first filter housing (pressure relief valve) to release air. Hold until water starts to escape and then release. Continue with next filter. Open valves on either side of purifier **slowly** and check for leaks (bypass valve should remain closed). Turn on any faucet to release air in the system, wait for a steady stream of water, then turn off faucet.

Plug the power cable from the ballast into an appropriate power source outlet (**a power surge suppressor rated at > 3600 Joules is strongly recommended**). Wait for the lamp to come on (up to 30 sec) and inspect the ballast and viewport, if present.

Now that system is operating properly, any incoming water is disinfected. Any existing pathogens downstream of the system, if present, are not affected. Therefore, **it is mandatory to disinfect the plumbing system downstream from the unit after installation** according to the instructions on Page 9.

UV Purification Systems



Setting Up / Maintenance

Disinfecting Your Water System

In any UV system, disinfection takes place inside the UV chamber and there is no residual disinfection agent remaining in the water stream. Pathogens that may still be present in the plumbing system downstream of the UV unit will not be affected by the disinfection process. For this reason, it is **CRITICAL** that the plumbing system is disinfected after initial installation to prevent possible re-contamination of the water on it's way to the taps.

The following steps must be taken to accomplish this important task.

- 1 Turn off the water supply to the UV unit and make sure that the by-pass valve is closed if equipped. Turn on the UV unit.
- 2 Remove the filter bowls from the filter housing head and remove the filter cartridges.
- 3 Fill one filter bowl one-half full with chlorine bleach and screw the bowls (without cartridges) back onto the filter housing head.
- 4 Turn on the water supply, check for leaks.
- 5 Turn on every tap in the water system of the building both inside and outside, one-by-one. Run the water at each tap until the smell of chlorine is evident. Let the system sit idle for 60 minutes.
- 6 While the UV lamp remains on, open all taps in the water system to flush out the chlorine - approximately 5 minutes.
- 7 When all chlorine is flushed from the system, and while the UV lamp remains on, shut off the water supply and reinstall the filter cartridges in the filter housings.
- 8 Turn on the water supply, check for leaks. Test water for contaminants.

WARNING

This simple procedure must be performed after installation of the UV system, and whenever the UV system is shut down or inoperative for any reason whatsoever.

UV Purification Systems



Maintenance

Ultraviolet Lamp Replacement

The UV lamp located in the purification chamber will operate effectively for approximately 1 year (9000 hours) under normal conditions. The lamp will still light after that period, but maximum UV light penetration may fall below the prescribed safety level.

Important:

It is required that the lamp be changed every 12 months after installation regardless of apparent condition of the lamp. **For warranty purpose use only original manufacturer replacement parts.**



Caution! Do not look directly at the UV.

- 1 Unplug the purifier from the electrical outlet. Note: It is not necessary to turn off the water supply. Do not use water.
- 2 With the Allen key provided, loosen the two set screws that secure the top cap containing the electrical cord. Remove the cap and carefully set aside (it is attached to the ground wire).
- 3 Remove the lamp connector located at the cord end of the lamp by gently wiggling and pulling away from the lamp.
- 4 Carefully slide the UV lamp out of the quartz dome/sleeve and discard appropriately.
- 5 Insert the replacement lamp into the quartz dome/sleeve. Hold lamp at ceramic ends. Do not touch the lamp with your hands - fingerprints will prevent the system from working properly. If the lamp is touched, clean with an alcohol wipe.
- 6 Gently push the lamp connector against the pins at the end of the new lamp.
- 7 Make sure that all electrical components are dry before replacing the top cap. Secure the cap with the setscrews.
- 8 Plug in the power cord. The lamp should be operating at this time. To confirm that your new lamp is working correctly, check your model's light indicator on the ballast and, if present, check the view port.

UV Purification Systems



Maintenance

Cleaning/Replacing the Quartz Dome or Sleeve

Important:

If water turbidity is a problem, it is advisable to clean the quartz dome/sleeve each time when replacing the lamp.

- 1 Turn off the water supply and open a faucet to depressurize the plumbing system. Unplug the purifier from the electrical outlet. Press the pressure-relief button on one of the filter housings. Horizontal mounted systems need to be drained by removing filter bowls. Have a bucket on hand.
- 2 With the Allen key provided, loosen the two set screws that secure the top cap containing the electrical cord. Remove the cap and carefully set aside (it is attached to the chamber with the ground wire).
- 3 Remove the white lamp pin connector from lamp end. Remove the UV lamp carefully from the UV unit.
- 4 Loosen and remove the sealing compression nut. Caution: Quartz dome/sleeve may be stuck to the O-ring inside the retaining nut.
- 5 Carefully remove the quartz dome/sleeve from the UV chamber.
- 6 Wipe the quartz dome/sleeve with nonabrasive cleaner (e.g. CLR or Limeaway) and with an alcohol wipe being careful not to touch the dome/sleeve with your fingers. You may choose to lubricate the O-ring with food-grade silicon or plumber's grease (do not use oil based products, such as Vaseline). Slide the O-ring onto the dome/sleeve.
- 7 Using a clean cloth to hold the end of the replacement quartz dome/sleeve, guide it gently into the UV chamber and screw the sealing compression nut down until snug to secure seal. Hand-tight only, **DO NOT USE TOOLS!**
- 8 Insert the replacement lamp into the quartz dome/sleeve. Gently push the lamp pin connector against the pins at the end of the lamp.
- 9 Complete the reassembly of the UV purifier. Make sure that all electrical parts are dry before replacing the top cap and securing it with the setscrews.
- 10 Plug in the ballast, turn on the water supply and check for leaks.

UV Purification Systems



Maintenance

Changing Filter Cartridges

Filter cartridges have to be changed on a frequent basis to ensure proper operation of the system. A pressure drop detected at the tap is an indication that the sediment filter cartridges is at capacity, and a re-occurrence of unwanted taste or odour is an indication that the carbon cartridge (if present) is exhausted.

Follow these steps to change out filter cartridges in your system.

- 1 Turn off the water supply. If isolation valves are installed at the unit, close them both.
- 2 Depress pressure release button to relieve pressure in filter housing. Unscrew housing with plastic wrench. Note: When opening filter housing, it is common for the O-ring/gasket to lift out of the housing and stick to cap.
- 3 Remove used cartridge and discard. Rinse out housing and fill approximately 1/3 full of water. Add about 2 to 3 teaspoons of bleach and scrub thoroughly with brush or sponge. Rinse thoroughly.
- 4 Remove O-ring/gasket from sump and wipe groove and O-ring/gasket clean. You may choose to lubricate O-ring/gasket with a coating of food grade silicon grease. Place O-ring/gasket back in place and press O-ring/gasket down into the groove with fingers (or place on rim of sump). Note: Make sure O-ring/gasket is seated level to maintain proper seal. If O-ring/gasket appears damaged, replace at this time.
- 5 Insert a new cartridge into the sump making sure that it slips down over the sump standpipe.
- 6 Screw the sump onto the cap and handtighten. Make sure that the cartridge slips over the cap standpipe.
- 7 Open shutoffs at the UV system (if present), open a faucet to depressurize the plumbing system, then turn on the water supply slowly to allow filter housing(s) to fill with water.
- 8 Depress the pressure release button (if present) to release trapped air from the filter housings.
- 9 Check for leaks before leaving installation. Filter sump may be gently tightened with plastic filter wrench if leaks occur. **DO NOT OVERTIGHTEN!**

UV Purification Systems



Maintenance

Filter Maintenance and Troubleshooting

Important:

Do not use filter with water that is microbiologically unsafe or of unknown quality without adequate disinfection before or after the unit.

An activated carbon cartridge (Taste/Odour) may contain a small amount of carbon fines (very fine black powder). A new cartridge should be flushed with sufficient water after installation to remove the fines before using the water.

Each time that you use water from your filtered water tap for drinking or cooking purposes, it is recommended that you run the tap for at least 10 seconds prior to using the water. This is important if the water tap is not used daily.

Replacement filter cartridges have a limited service life. Changes in taste, colour and flow of the water being filtered are signals that replacement of the cartridge is imminent or may soon be necessary.

CAUTION: The filter must be protected against freezing. Failure to do so may result in cracking of the filter and water leakage.

CAUTION: All filtration systems contain other parts that have a limited service life. Exhaustion of the service life of those parts often cannot be easily detected. Commonly, it is only after leakage has been observed or water damage has occurred that one is made aware that the service life has been exhausted.

IMPORTANT NOTICE: To prevent costly repairs or possible water damage, we recommend that the bowl or sump of all plastic housings be replaced periodically: at least every 5 years for clear sumps, and every 10 years for opaque sumps.

UV Purification Systems

UV-1

Technical Info

Exploded Diagram & Parts List

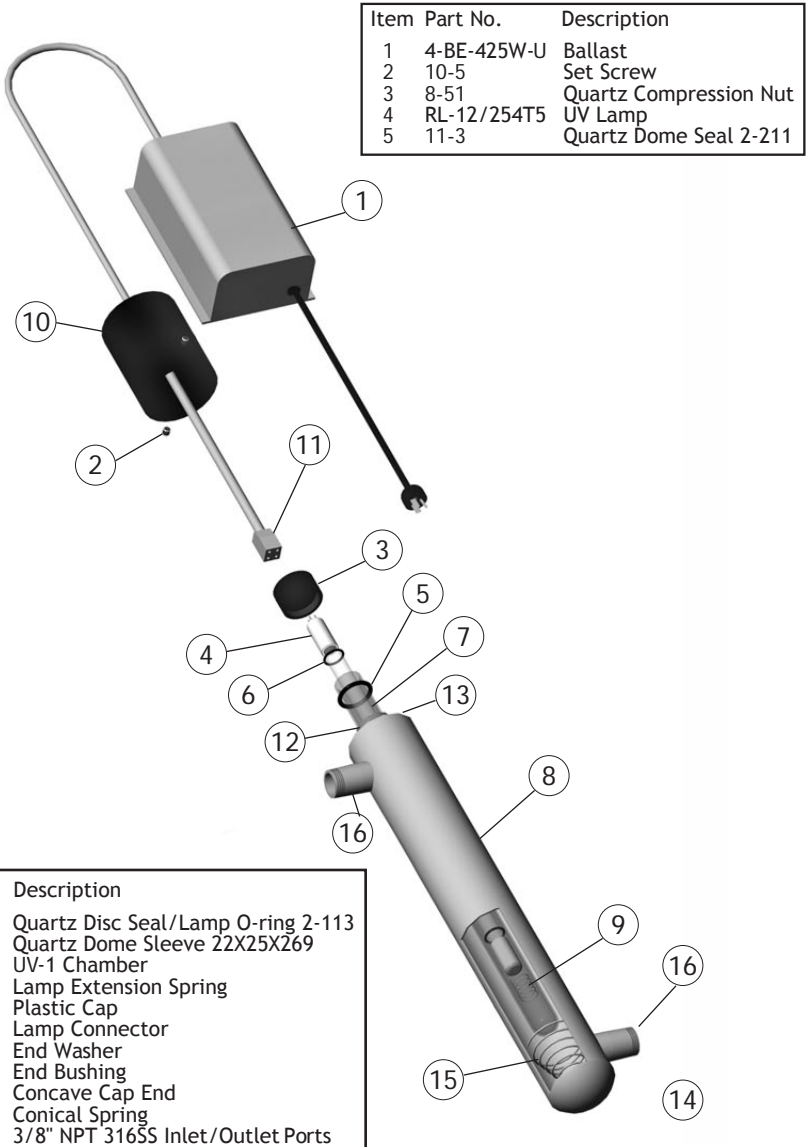

UV Purification Systems

UV-250

Technical Info

Exploded Diagram & Parts List

Item	Part No.	Description
1	4-BE-425W-U	Ballast
2	10-5	Set Screw
3	8-51	Quartz Compression Nut
4	RL-23/436T5	UV Lamp
5	11-3	Quartz Dome Seal 2-211

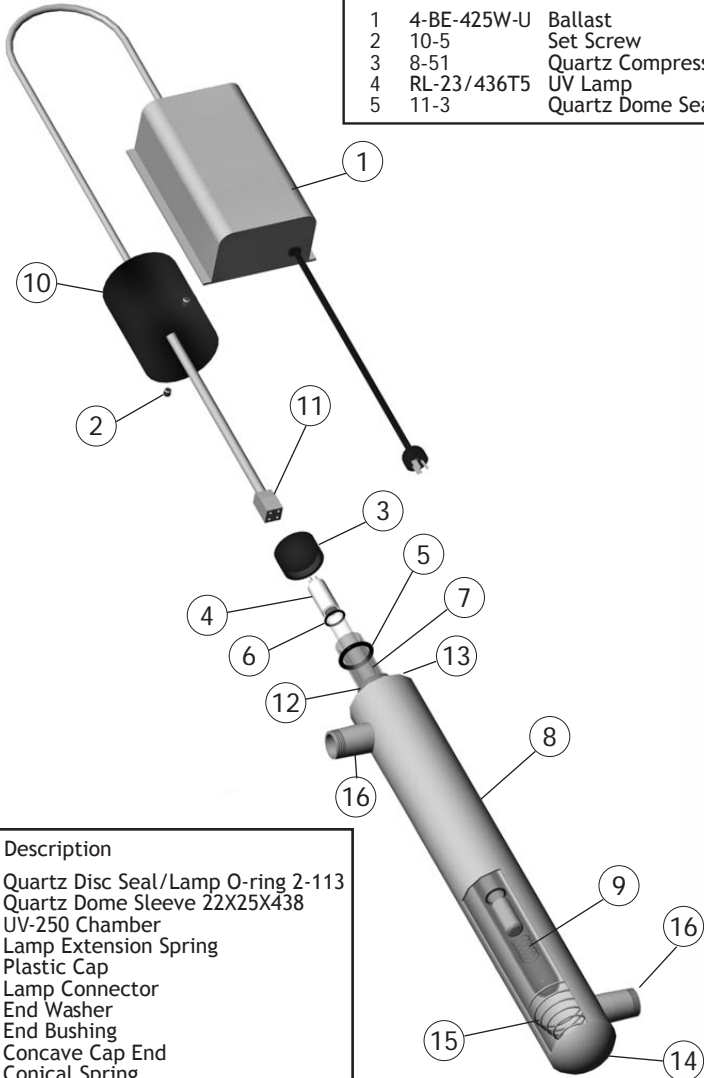

Item	Part No.	Description
6	11-6	Quartz Disc Seal/Lamp O-ring 2-113
7	RQD-438	Quartz Dome Sleeve 22X25X438
8	2-2	UV-250 Chamber
9	8-29-1	Lamp Extension Spring
10	8-4-1	Plastic Cap
11	4-2	Lamp Connector
12	8-50	End Washer
13	8-52	End Bushing
14	8-49-1	Concave Cap End
15	8-25	Conical Spring
16	8-5	3/4" NPT 316SS Inlet/Outlet Ports

UV Purification Systems

UV-700

Technical Info

Exploded Diagram & Parts List

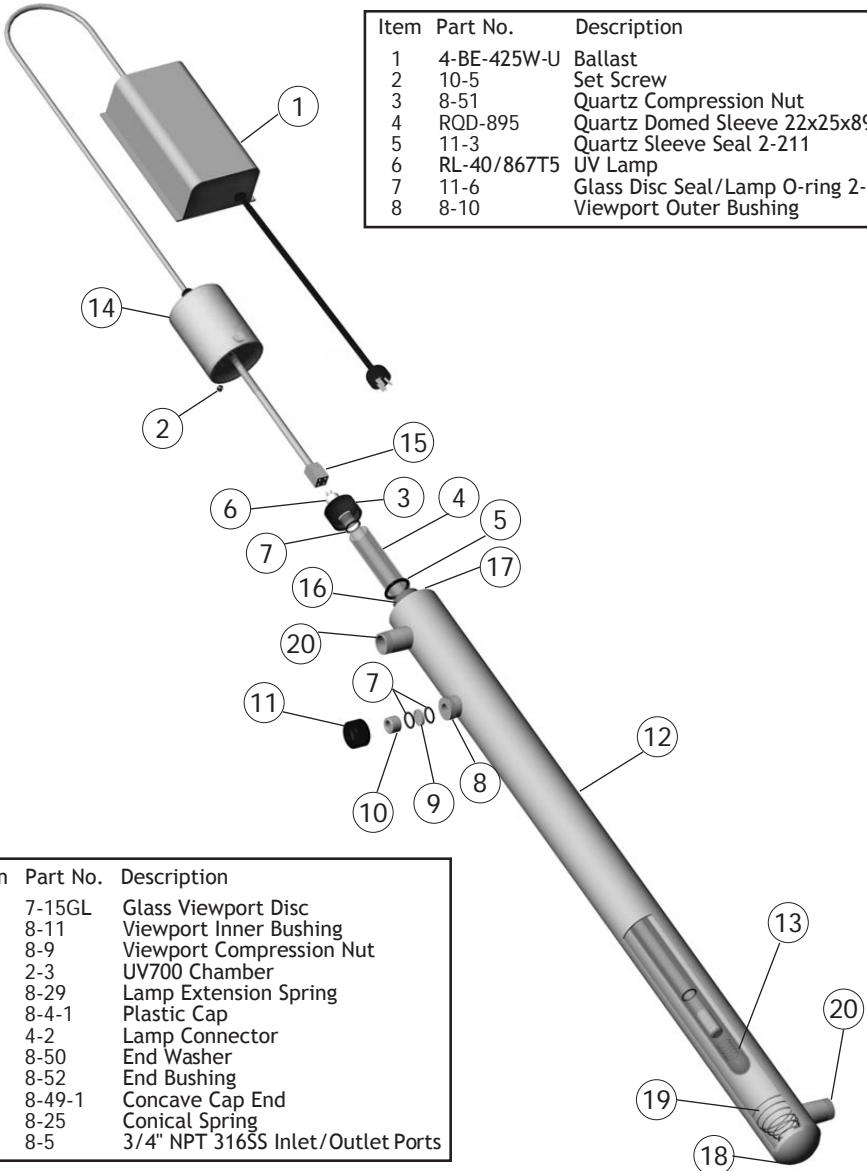

Item	Part No.	Description
1	4-BE-425W-U	Ballast
2	10-5	Set Screw
3	8-51	Quartz Compression Nut
4	ROD-895	Quartz Domed Sleeve 22x25x895
5	11-3	Quartz Sleeve Seal 2-211
6	RL-40/867T5	UV Lamp
7	11-6	Glass Disc Seal/Lamp O-ring 2-113
8	8-10	Viewport Outer Bushing

Item	Part No.	Description
9	7-15GL	Glass Viewport Disc
10	8-11	Viewport Inner Bushing
11	8-9	Viewport Compression Nut
12	2-3	UV700 Chamber
13	8-29	Lamp Extension Spring
14	8-4-1	Plastic Cap
15	4-2	Lamp Connector
16	8-50	End Washer
17	8-52	End Bushing
18	8-49-1	Concave Cap End
19	8-25	Conical Spring
20	8-5	3/4" NPT 316SS Inlet/Outlet Ports

UV Purification Systems

UV-1200

Technical Info

Exploded Diagram & Parts List

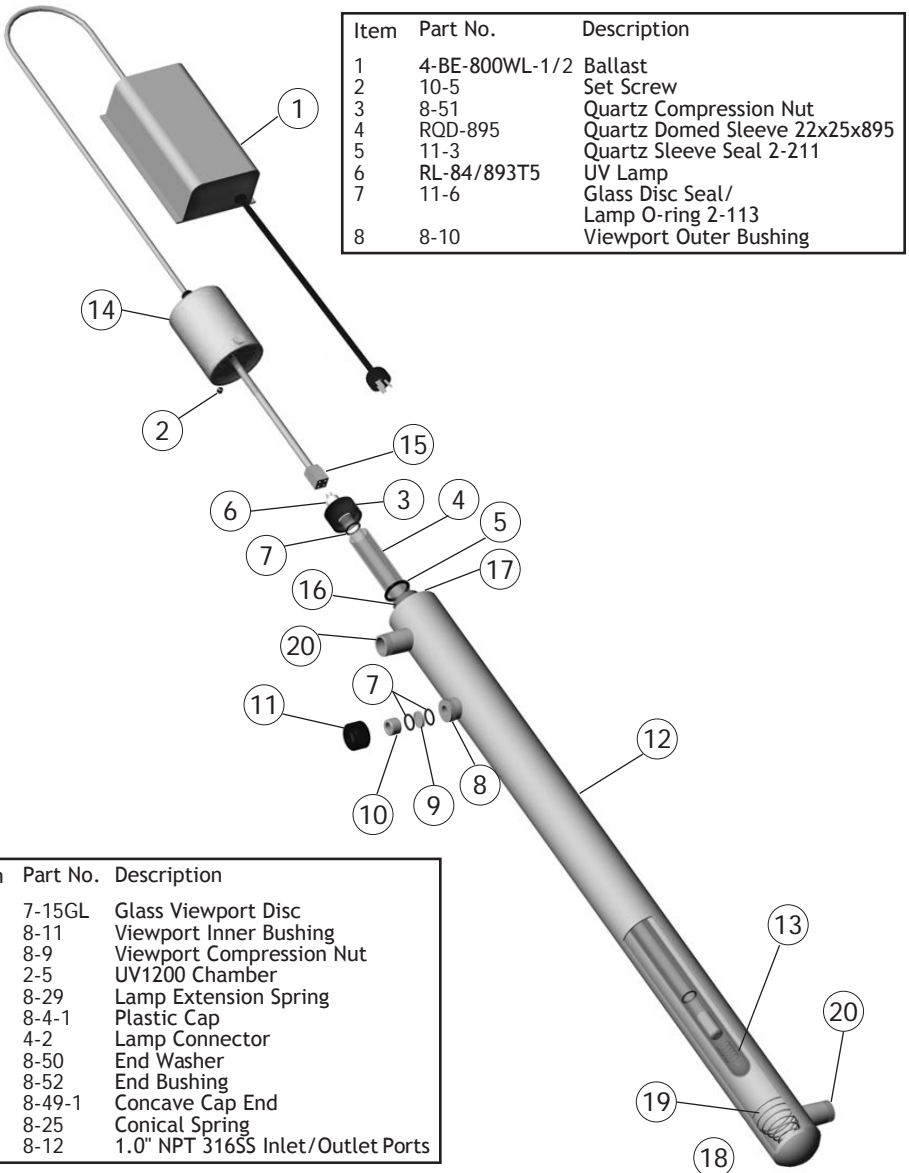

Item	Part No.	Description
1	4-BE-800WL-1/2	Ballast
2	10-5	Set Screw
3	8-51	Quartz Compression Nut
4	ROD-895	Quartz Domed Sleeve 22x25x895
5	11-3	Quartz Sleeve Seal 2-211
6	RL-84/893T5	UV Lamp
7	11-6	Glass Disc Seal/ Lamp O-ring 2-113
8	8-10	Viewport Outer Bushing

Item	Part No.	Description
9	7-15GL	Glass Viewport Disc
10	8-11	Viewport Inner Bushing
11	8-9	Viewport Compression Nut
12	2-5	UV1200 Chamber
13	8-29	Lamp Extension Spring
14	8-4-1	Plastic Cap
15	4-2	Lamp Connector
16	8-50	End Washer
17	8-52	End Bushing
18	8-49-1	Concave Cap End
19	8-25	Conical Spring
20	8-12	1.0" NPT 316SS Inlet/Outlet Ports

UV Purification Systems

UV-1500

Technical Info

Exploded Diagram & Parts List

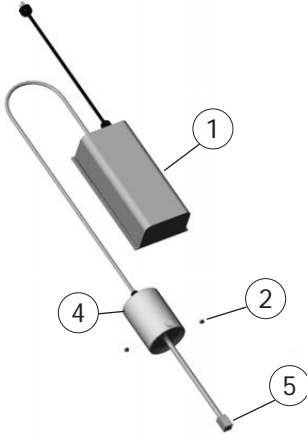

Item	Part No.	Description
1	4-BE-800WL-1/2	Ballast
2	10-5	Set Screw
3	8-53	Quartz Compression Nut
4	8-4-1	Large Blue Cap
5	4-2	Lamp Connector
6	RL-110/1197T5	UV Lamp
7	RQS-1181	Quartz Open Sleeve 22x25x1181
8	11-6	Glass Disc Seal/ Lamp O-ring 2-113
9	11-3	Quartz Sleeve Seal 2-211
10	8-52	End Bushing
11	8-50	End Washer
12	8-12	1.0" NPT 316SS Inlet/Outlet Ports

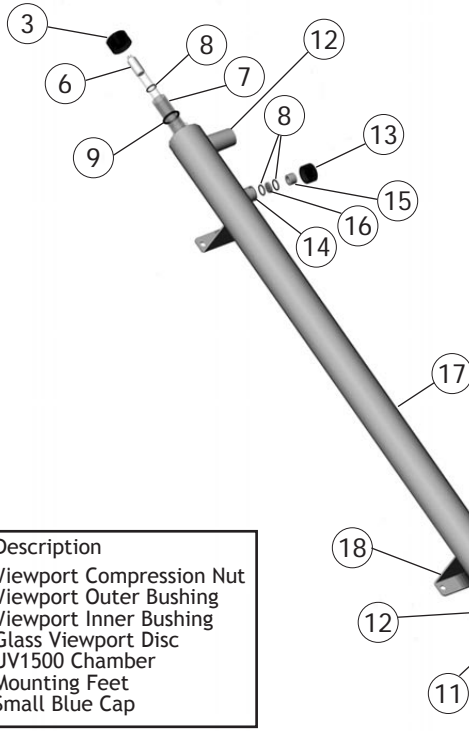

Item	Part No.	Description
13	8-9	Viewport Compression Nut
14	8-10	Viewport Outer Bushing
15	8-11	Viewport Inner Bushing
16	7-15GL	Glass Viewport Disc
17	2-4	UV1500 Chamber
18	5-2	Mounting Feet
19	8-4	Small Blue Cap

UV Purification Systems

UV-3000

Technical Info

Exploded Diagram & Parts List

Item	Part No.	Description
1	4-BE-800WL30-1/2	Ballast
2	10-5	Set Screw
3	8-40	Black End Cap
4	8-301	Quartz Compression Nut
5	11-10	Lamp O-ring 19x6
6	RL-100/1197T6	UV Lamp
7	RQS-1190	Quartz Open Sleeve 32x36x1190
8	11-324	Quartz Sleeve Seal 2-324
9	8-30	End Flange
10	8-302	Threaded End Bushing

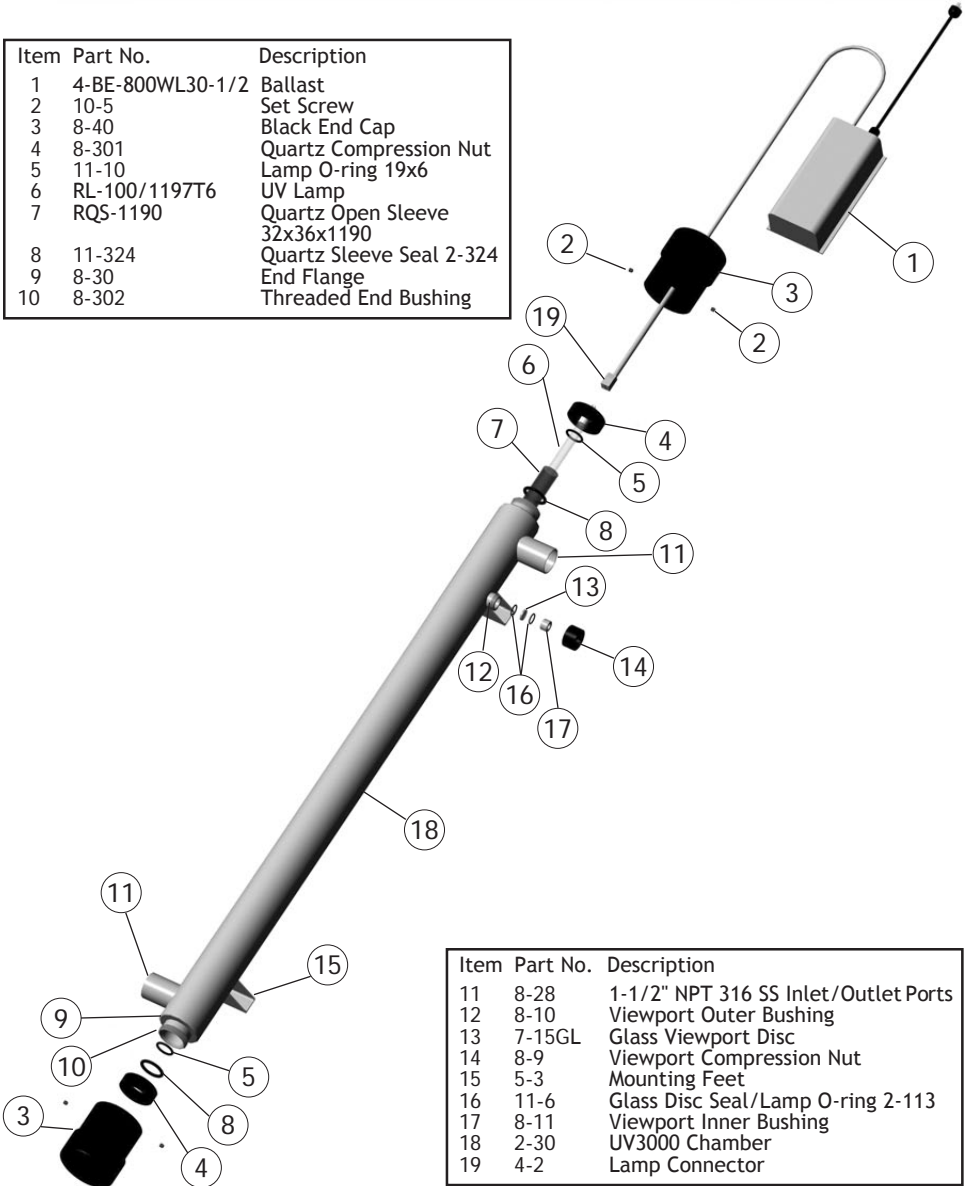

Item	Part No.	Description
11	8-28	1-1/2" NPT 316 SS Inlet/Outlet Ports
12	8-10	Viewport Outer Bushing
13	7-15GL	Glass Viewport Disc
14	8-9	Viewport Compression Nut
15	5-3	Mounting Feet
16	11-6	Glass Disc Seal/Lamp O-ring 2-113
17	8-11	Viewport Inner Bushing
18	2-30	UV3000 Chamber
19	4-2	Lamp Connector

UV Purification Systems

UV-5000

Technical Info

Exploded Diagram & Parts List

Item	Part No.	Description
1	4-BE-800WL-1/2	Ballast
2	10-5	Set Screw
3	8-53	Quartz Compression Nut
4	RL-110/1197T5	UV Lamp
5	11-6	Quartz Disc Seal/ Lamp O-ring 2-113
6	11-3	Quartz Sleeve Seal 2-211
7	RQS-1181	Quartz Open Sleeve 22X25X1181
8	2-6	UV5000 Chamber
9	8-11	Viewport Inner Bushing

in newer UV-5000 Systems,
the view port assemblies are
located on top of the chamber

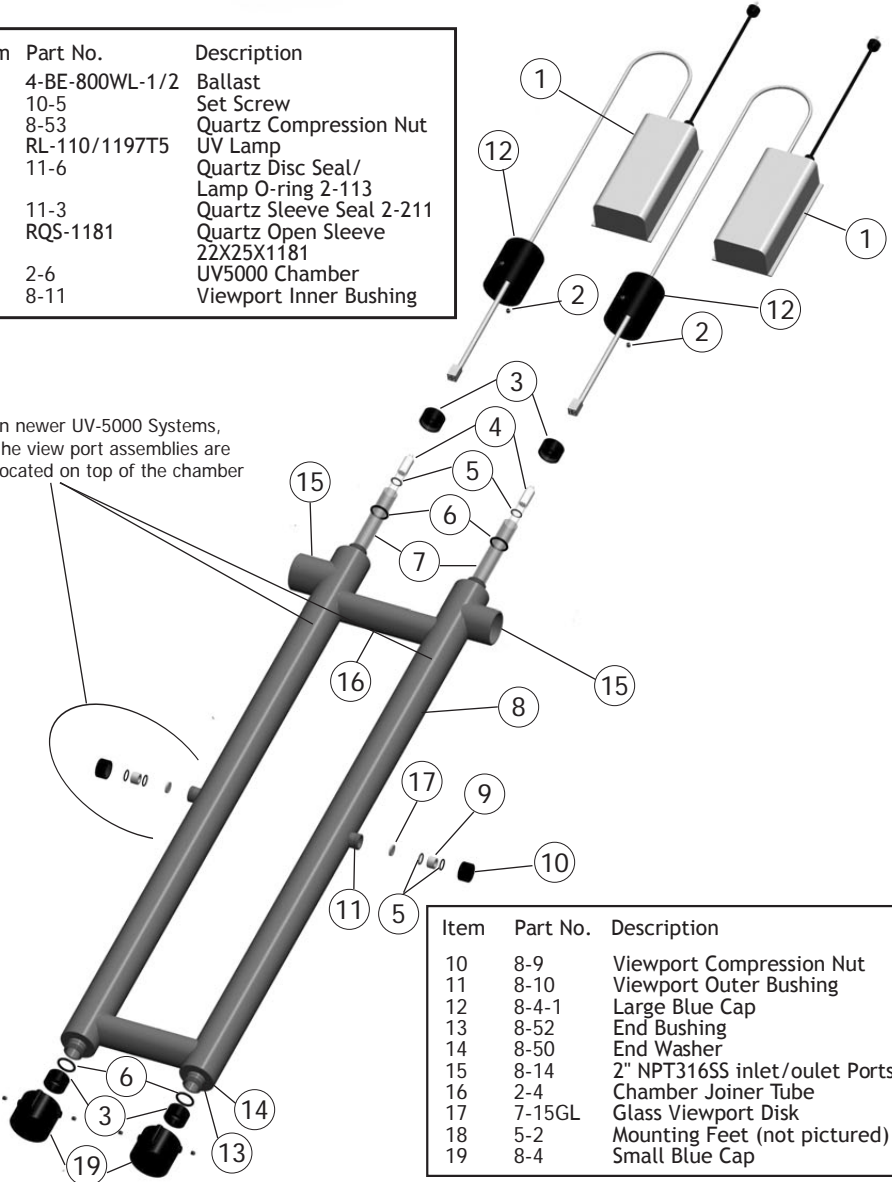

Item	Part No.	Description
10	8-9	Viewport Compression Nut
11	8-10	Viewport Outer Bushing
12	8-4-1	Large Blue Cap
13	8-52	End Bushing
14	8-50	End Washer
15	8-14	2" NPT316SS inlet/outlet Ports
16	2-4	Chamber Joiner Tube
17	7-15GL	Glass Viewport Disk
18	5-2	Mounting Feet (not pictured)
19	8-4	Small Blue Cap

UV Purification Systems

UV-6000

Technical Info

Exploded Diagram & Parts List

Item	Part No.	Description
1	4-BE-800W30L-1/2	Ballast
2	10-5	Set Screw
3	8-301	Quartz Compression Nut
4	RL-100/1197T6	UV Lamp
5	11-10	Lamp O-ring 19x6
6	11-324	Quartz Sleeve Seal 2-324
7	RQS-1190	Quartz Open Sleeve 22X25X1190
8	2-60	UV6000 Chamber
9	8-11	Viewport Inner Bushing

in newer UV-6000 Systems,
the view port assemblies are
located on top of the chamber

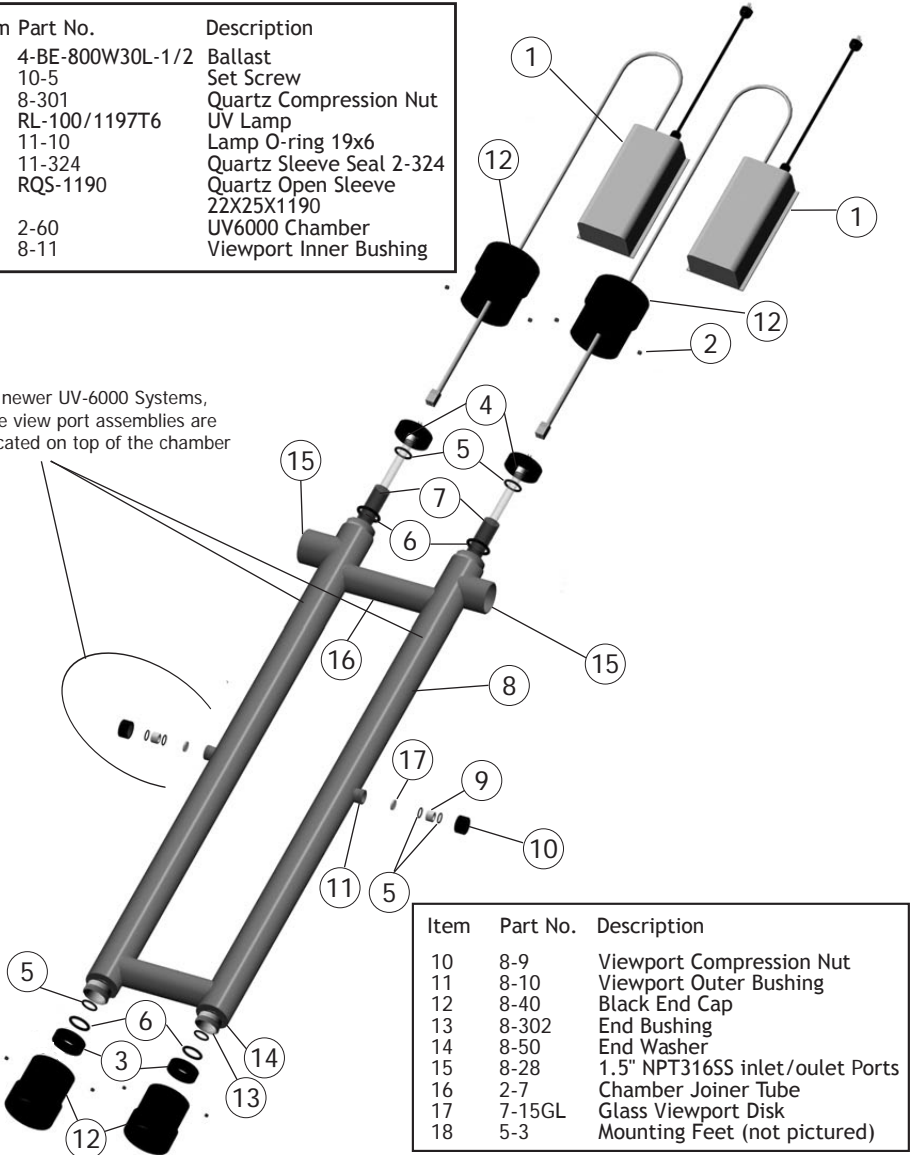

Item	Part No.	Description
10	8-9	Viewport Compression Nut
11	8-10	Viewport Outer Bushing
12	8-40	Black End Cap
13	8-302	End Bushing
14	8-50	End Washer
15	8-28	1.5" NPT316SS inlet/outlet Ports
16	2-7	Chamber Joiner Tube
17	7-15GL	Glass Viewport Disk
18	5-3	Mounting Feet (not pictured)

UV Purification Systems



Maintenance

Troubleshooting Guide

Trouble	Cause	Solution
UV Lamp will not light	Input voltage below or above 120/240 volts Line cord disconnected or outlet defective Breaker/fuse has blown Defective UV Lamp Defective Lamp Ballast	Install a voltage regulator Check or replace Check or replace Replace Check that indicator light is on Check output voltage Check that white lamp end connector is secure on lamp pins
Leak at quartz sleeve	Defective or cracked O-ring O-ring not seated properly Quartz fracture	Lubricate or replace O-ring Replace O-ring Replace quartz sleeve

If problem persists, call Wyckomar Inc. for technical assistance.
 1.800.419.5162 or 519.822.1886 email sales@wyckomaruv.com

UV Purification Systems



Accessories

Filter Sets and Cartridges

Filter Sets are available in standard 10" and 20" configurations, in SlimLine and BigBlue sizes. For commercial applications with higher flow rates, stainless steel filter housings are available. We HIGHLY recommend a 5 micron sediment and a carbon filter be installed ahead of the UV unit in order to ensure proper UV operation. Commercial grade filter systems for higher flow rates are also available

Sediment and carbon filter cartridges are available from Wyckomar. Other types of filter cartridges for the removal of various contaminants are also available (arsenic, fluoride, etc). Minerals and dissolved solids have an effect on the clarity of the water and therefore on the efficacy of the UV disinfection process. If elevated levels of these contaminants are present, additional equipment may be needed to reduce/remove them from the water. Please refer to the Section "Factors affecting UV Purification" on Page 2.

Be sure to replace filter cartridges on a regular basis to ensure proper operation of your UV disinfection system.



10" Filter Set
SlimLine



20" Filter Set
SlimLine



20" Filter Set
BigBlue



Filter Cartridges



Filter Housings for
UV-5000 and UV-6000

UV Purification Systems



Accessories

UV Monitoring System

A Wyckomar UV Monitor (available separately) measures true UV intensity at 254 nm, which is the effective germicidal wavelength for UV treatment of drinking water. It continuously monitors lamp output inside the reaction chamber through a sensor in the viewport, regardless of whether or not water is flowing through the system. UV intensity is constantly displayed in real-time on the meter face on the monitor device. If the UV intensity emitted by the lamp drops below the alarm set-point (70% of new lamp UV output), the audible alarm will sound. An optional solenoid valve may be connected to the monitor to stop the water flow.

The UV Monitor is available with volt-free contacts for remote signaling of operation, and also with 4-20mA output for remote operation logging (see Page 25).

Installation instructions are supplied with the UV Monitor.



UV Purification Systems



Accessories

Remote Output and Operation Logging

An electronic ballast and a monitor can be equipped with volt-free contacts to allow remote signalling of the operation. This allows to incorporate the UV system into the work-flow of a large water treatment system that is centrally operated through a BMS (building management system).

A UV Monitor with 4-20 mA output for remote operation logging in a PLC is also available.



UV Purification Systems



Accessories

Purge Valve, Hour Meter

Thermo-Sensitive Purge Valve

During times of no-flow, some UV systems will warm up, as there is no cool water flowing through the chamber to cool the lamp. This is normal.

Increased temperature of the water means reduced UV output, as hot lamps do not produce as much germicidal output as cool lamps do. This may result in the UV system going into alarm state, if it is equipped with a UV Monitor.

The solution to this problem is to install a thermo-sensitive purge valve at the out port of the UV system. It will automatically open and drain water from the chamber, to allow cool water to replace it and maintain high UV output of the lamp. No power is required.



Purge Valve

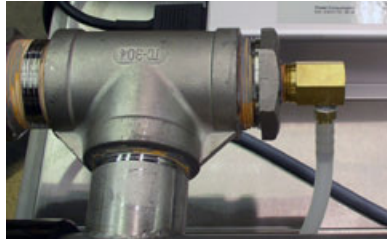

Installation on the Out Port with a T-Fitting

Hour Meter

The electronic ballast of any Wyckomar UV system can be equipped with an optional resettable hour meter, displaying the total run time of the lamp. This is convenient for ensuring that the lamp is not used after the germicidal output has decreased to less than 70% of the output of a new lamp (after 9000 hours of operation).



Ballast with Hour Meter Installed



UV Purification Systems

Questions?



Contact and Warranty Information

Congratulations on purchasing a Wyckomar UV purification system. We want you to be satisfied with your product and with our service. If you need to contact a Wyckomar Customer Service Representative, please have your product model number and serial number ready.

For warranty service, please contact us for an RMA number and ship defective product, along with proof of purchase indicating the date of purchase and a letter describing the problem, to:

Mail:	Wyckomar Inc. 111 Malcolm Road Guelph, Ontario, CANADA N1K 1A8
Telephone:	1.800.419.5162 519.822.1886
Fax:	519.763.6580
Email:	sales@wyckomaruv.com
Web Site:	www.wyckomaruv.com

For this warranty to be effective, when making a warranty claim you must include your proof of purchase receipt indicating the date of purchase

Wyckomar Inc. warrants to the first purchaser of the UV unit that the UV reactor chamber will be free from faulty material and/or workmanship for a period of 5 years from date of purchase. Ballasts, UV Monitors and UV Lamps carry a one-year pro-rated warranty from date of purchase.

Wyckomar Inc.'s liability during the warranty period is limited to the repair and/or replacement of the part(s), which prove to be defective in material and/or workmanship under normal use. Shipping, handling and service costs are the responsibility of the purchaser. The defective part or unit must be returned to Wyckomar at the purchaser's expense.

The warranty is not transferable and is the only warranty authorized by Wyckomar Inc. Any other warranty or guarantee, implied or offered, will not be honored by Wyckomar Inc.

This warranty is void, if in the opinion of Wyckomar Inc. that the product failure was caused by misuse, abuse, accident or improper installation. Do not install systems out of doors (in the elements). All units are for indoor use only in a dry location.

As a result of this warranty, Wyckomar Inc. is not responsible for any damages, injuries or losses whatsoever, including those incurred during installation, repair or replacement, as well as incidental or consequential damages.

UV Purification Systems



Warranty Registration Card

Please fill out your Wyckomar Product Registration Card and return it to the manufacturer. Alternatively, you may email the information to sales@wyckomaruv.com or fill the form out online at www.wyckomaruv.com/Warranty.html

Last Name

First Name

Street Address

City

Province/State

Postal Code/Zip

Country

Phone Number

Date of Purchase

email Address

Product Model Number

Product Serial Number

Purchased From

This unit is installed

in a residential building

in a commercial business

on a municipal water supply

on a private well

Wyckomar

means
chemical-free

Wyckomar Inc. has been manufacturing
Chemical-Free Ultra Violet
Water Purification and Filtration Systems
since 1978

Currently, we sell our products in more than
25 countries around the globe. Our products are very
environmental-friendly by reducing or eliminating the
need for chemical-based water disinfection systems.

For information on distribution opportunities, including
our internet affiliate network, please contact our sales
department.

sales@wyckomaruv.com

<http://www.wyckomaruv.com>





111 Malcolm Road
Guelph, Ontario
Canada N1K 1A8
Ph. ++1-519-822-1886
Fx. ++1-519-763-6580
www.wyckomaruv.com
sales@wyckomaruv.com