

# INSTALLATION MANUAL & OWNER'S GUIDE

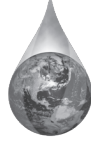

# Pura

## Stainless Steel Ultraviolet Water Purification System

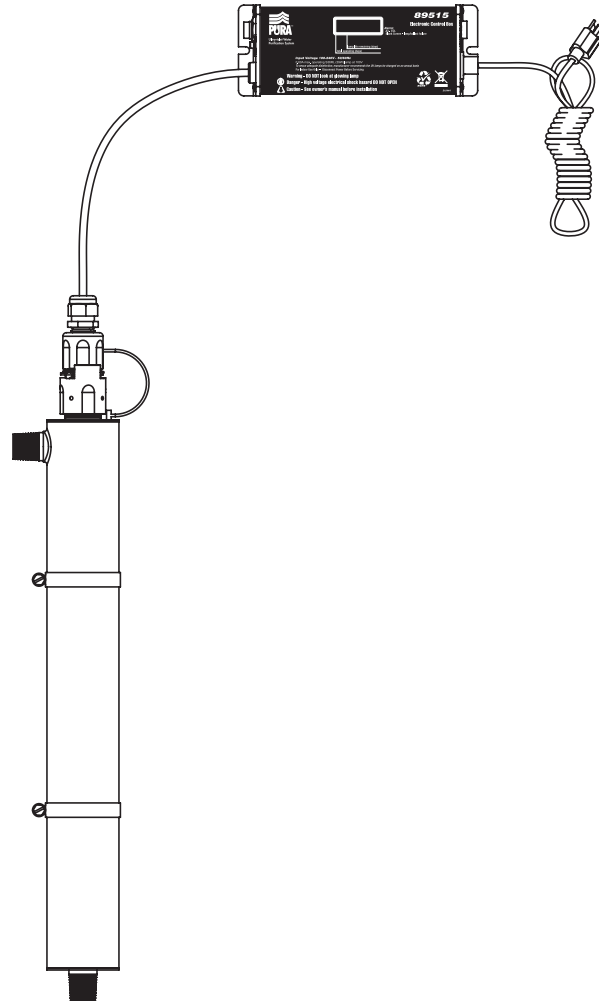

**UVSS-6**  
**UVSS-10**  
**UVSS-15**

**UVSS-6M**  
**UVSS-10M**  
**UVSS-15M**

# Specifications

Item #	Model#	Flow Rate** @ 16 mJ/cm <sup>2</sup> usgpm (L/min)	Flow Rate** @ 30 mJ/cm <sup>2</sup> usgpm (L/min)	Flow Rate** @ 40 mJ/cm <sup>2</sup> usgpm (L/min)	Power Consumption Watts	Lamp Watts	Inlet/ Outlet Size	UV Chamber Size (D x L) inches (cm)	Control Box Size (L x W x H) inches (cm)	Weight lbs (kg)
8750	UVSS-6	11 (41.63)	6 (22.71)	4.5 (17)	30	25	3/4" NPT	2.5"(6.35) x 22.07"(57.6)	7.3"(18.54) x 3.15"(8) x 2.52"(6.4)	7 (3.18)
8751	UVSS-10	20 (75.7)	10 (37.85)	7.7 (29.14)	46	37	3/4" NPT	2.5"(6.35) x 35.7"(90.6)	7.3"(18.54) x 3.15"(8) x 2.52"(6.4)	11 (5)
8752	UVSS-15	29 (109.76)	15 (56.77)	11 (41.63)	48	39	1" NPT	3.5"(8.9) x 38.1"(96.7)	7.3"(18.54) x 3.15"(8) x 2.52"(6.4)	14 (6.36)
8753	UVSS-6M	11 (41.63)	6 (22.71)	4.5 (17)	30	25	3/4" NPT	2.5"(6.35) x 22.07"(57.6)	8.3"(21) x 3.15"(8) x 2.52"(6.4)	8 (3.63)
8754	UVSS-10M	20 (75.7)	10 (37.85)	7.7 (29.14)	46	37	3/4" NPT	2.5"(6.35) x 35.7"(90.6)	8.3"(21) x 3.15"(8) x 2.52"(6.4)	12 (5.45)
8755	UVSS-15M	29 (109.76)	15 (56.77)	11 (41.63)	48	39	1" NPT	3.5"(8.9) x 38.1"(96.7)	8.3"(21) x 3.15"(8) x 2.52"(6.4)	15 (6.81)

\*Flow rates stated at 96% UVDEOL. The manufacturer reserves the right to make product improvements which may deviate from the specifications and descriptions stated herein, without obligation to change previously manufactured products or to note the change.

You have purchased one of the most technologically advanced Ultraviolet Water Treatment System available anywhere in the world. It has been designed with you, the consumer, in mind. PURA® products are lightweight, easy to use, and simple to maintain. PURA products will provide you with healthy, clean drinking water for years to come.

## What is Ultraviolet?

Ultraviolet (UV) light from the sun has long been known for its ability to destroy microorganisms. However, it has only been in recent years that equipment producing UV light has been manufactured for residential use.

UV energy is produced by low-pressure mercury vapor enclosed in a tubular lamp. While a UV lamp resembles a standard fluorescent lamp, it is similar in appearance only.

Energy produced by the UV lamp has the ability to destroy microorganisms that can live in water. There are

five major groups of microorganisms that are altered by a specific spectrum of ultraviolet light: viruses, bacteria, fungi, algae, and protozoa.

When these microbes are exposed to the proper amount of UV energy, their DNA structure is scrambled, and they are unable to reproduce. Since the cell is now sterile or dead, it is no longer a threat.

## PURA Systems

PURA recommends that all UV systems include pre-filters to process the water before it reaches the UV lamp. This will ensure that maximum UV exposure is achieved.

PURA Ultraviolet Water Treatment Systems are designed for indoor use only.

PURA Systems are designed to provide complete water treatment in a compact, easy-to-use package. Please follow the directions in this Guide exactly when installing your PURA System to ensure that it operates correctly.

# Safety Instructions

## WARNING

To guard against injury, basic safety precautions should be observed, including the following:

1. **READ AND FOLLOW ALL SAFETY INSTRUCTIONS.**
2. **CAUTION** - Always disconnect power before servicing.
3. **DANGER** - To avoid possible electric shock, special care should be taken since water is present near electrical equipment. Unless a situation is encountered that is explicitly addressed by the provided maintenance and troubleshooting sections, do not attempt repairs by yourself, refer to an authorized service facility.
4. Carefully examine the disinfection system after installation. It should not be plugged in if there is water on parts not intended to be wet such as, the ballast or lamp connector.
5. Do not operate the disinfection system if it has a damaged cord or plug, if it is malfunctioning or if it has been dropped or damaged in any manner.
6. Always disconnect water flow and unplug the disinfection system before performing any cleaning or maintenance activities. Never yank the cord to remove from an outlet; grasp the wall plug and pull to disconnect.
7. Do not use this disinfection system for other than intended use (potable water applications). The use of attachments not recommended or sold by the manufacturer/distributor may cause an unsafe condition.
8. Intended for indoor use only. Do not install this disinfection system where it will be exposed to the weather or to temperatures below freezing. Do not store this disinfection system where it will be exposed to the weather or to temperatures below freezing unless all water has been drained from it and the water supply has been disconnected.
9. Read and observe all the important notices and warnings on the water disinfection system.
10. If an extension cord is necessary, a cord with a proper rating should be used. A cord rated for less Amperes or Watts than the disinfection system rating may overheat. Care should be taken to arrange the cord so that it will not be tripped over or pulled. Circuit breaker must not exceed power cord current rating (ie - 15A for North American NEMA 5-15P).
11. **SAVE THESE INSTRUCTIONS**

**WARNING:** The UV light given off by this unit can cause serious burns to unprotected eyes and skin. Never look directly at an illuminated UV lamp. When performing any work on the UV disinfection system always unplug the unit first. Never operate the UV system while the UV lamp is outside of the UV chamber.

Note: The UV lamp inside the disinfection system is rated at an effective life of approximately 9000 hours. To ensure continuous protection, replace the UV lamp annually.

## Conditions For Use

Iron (Fe)	< 0.3 ppm (0.3 mg/L)
Hardness*	< 7 gpg (120 mg/L)
Turbidity	< 1.0 NTU
Manganese (Mn)	< 0.05 ppm (0.05 mg/L)
Tannins	< 0.1 ppm (0.1 mg/L)
UV Transmittance	> 75%**

\*Where total hardness is less than 7 gpg, the UV unit should operate efficiently provided the quartz sleeve is cleaned periodically. If total hardness exceeds 7 gpg, the water should be softened.  
 \*\*Call customer service for recommendations on applications where UVT < 75%.

Water quality is extremely important for the optimum performance of your UV system. The following levels are recommended for installation:

If your water chemistry contains levels in excess of those mentioned above, proper pre-treatment is recommended to correct these water problems prior to the installation of your UV disinfection system. These water quality parameters can be tested by your local dealer, or by most private analytical laboratories. **Proper pre-treatment is essential for the UV disinfection system to operate as intended.**

## Installing Your UV Disinfection System

### CAUTION

Electronic ballast must be connected to a grounded receptacle and the lamp connector ground wire connected to the stainless steel reactor chamber.

- The disinfection system is designed to be mounted either horizontally or vertically at the point-of-use or point-of-entry depending on the specific flow rate of the unit.

Note: The ideal installation is vertical with the lamp connector at the top. This is to prevent water damage from occurring on the lamp pins and lamp connector.

- The ballast should be mounted either above or beside the reactor chamber. Never mount vertically with AC connector at top of ballast to prevent moisture from running down cordage and causing a potential fire hazard. Drip loops in all cordage connected to ballast controller is highly recommended (see Figure 1D).
- The complete water system, including any pressure or hot water tanks, must be sterilized before start up by flushing with chlorine (household bleach) to destroy any residual contamination (see page 4).
- For safety purposes, the disinfection system should be connected to a ground fault interrupt circuit.
- The disinfection system is intended for indoor use only, do not install disinfection system where it may be exposed to the outdoor weather.
- Install the disinfection system on cold water line only.
- If treating the entire house, install the disinfection system before any branch lines.
- A 5 micron sediment filter must precede the disinfection system. Ideally, the disinfection system should be the last treatment the water receives before it reaches the faucet.

### Typical Installation

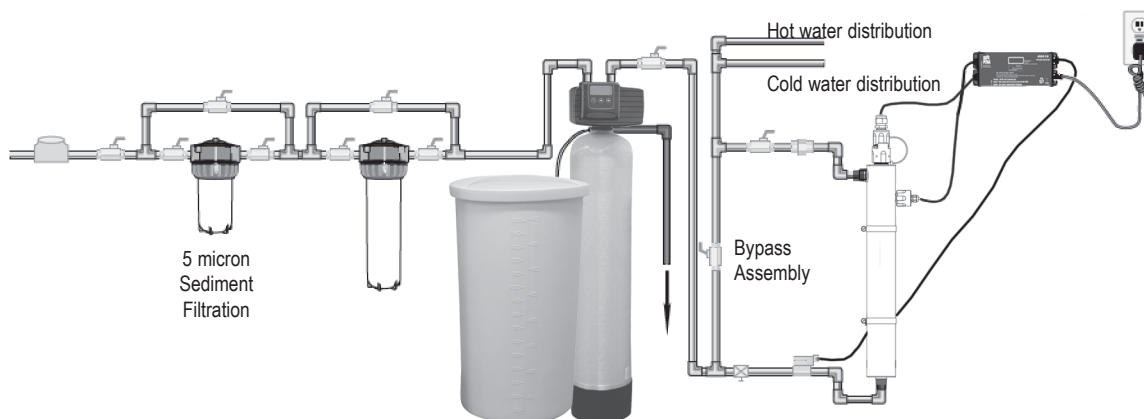

Figure 1 - Typical installation of disinfection system and the related components that may be used for the installation

1. The use of a bypass assembly is recommended in case the system requires 'off-line' maintenance. If this is the case, it must be noted that the system will require supplementary disinfection of the distribution system if any water is used during this bypass condition. In addition, during bypass, the water will NOT be disinfected until such time as the system is sanitized and returned to service. Please refer to the complete disinfection procedure as outlined on page 4 of this document. If the water is to be offline, the water must be boiled for twenty minutes prior to consumption.
2. Select a suitable location for the disinfection system and its related components. As it is recommended to install a ground fault protected circuit (GFCI), make sure that this is taken into consideration prior to any installation. The system can either be installed vertically (inlet port at the bottom) (Figure 1A), or horizontally (Figure 1B), however the vertical installation is the most preferred method. When selecting a mounting location, you must also leave enough space to allow for the removal of the UV lamp and/or quartz sleeve (typically leave a space equal to the size of the reactor chamber itself).

### Pre-Installation Instructions

The figure below shows the proper water flow for horizontal or vertical installation. Make certain that your unit and the inlet and outlet pipes are in the right position for either horizontal or vertical installation

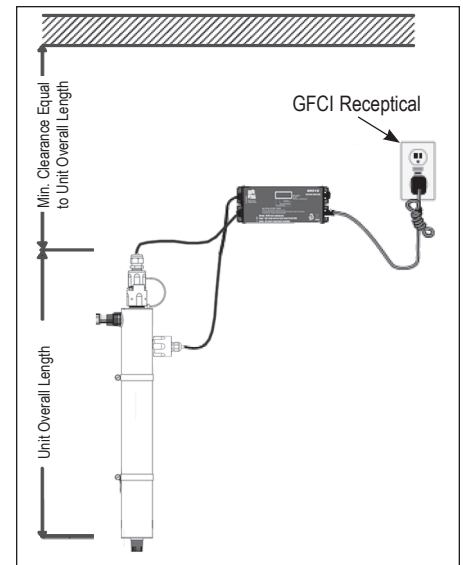
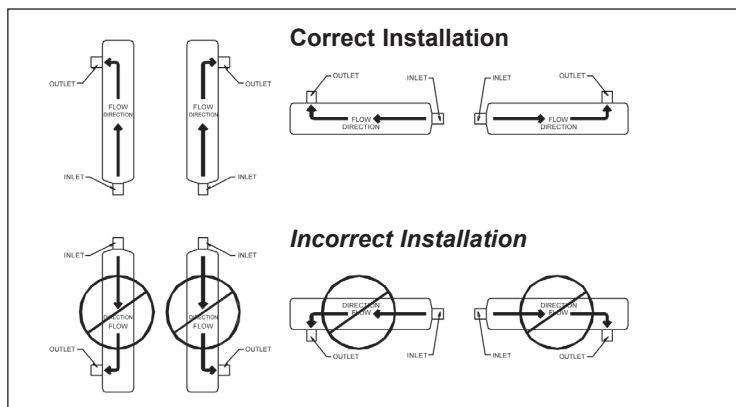

Figure 1A

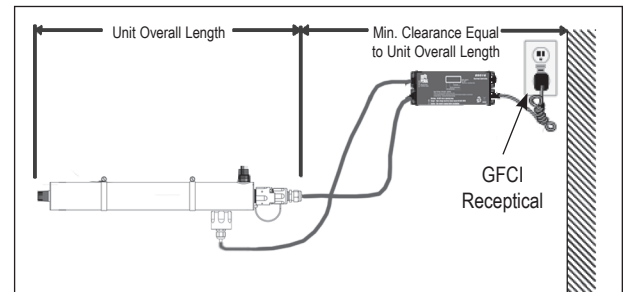

Figure 1B

**IMPORTANT:** For vertical installation, the inlet is at the bottom and the outlet is near the top of the disinfection chamber. For horizontal installation, pay careful attention to the diagram for flow direction.

3. Mount the system to the wall using the supplied clamps. Various connection methods can be used to connect the water source to the system, however union type connectors are recommended. The use of a flow restrictor device is strongly recommended when installing your system in order to maintain the manufacturers rated flow rate. The flow restrictor should be installed on the outlet port and is designed to be installed in one direction only. Ensure that the flow of the water matches the flow direction as indicated on the flow restrictor (Figure 1C). DO NOT SOLDER CONNECTIONS WHILE ATTACHED TO THE SYSTEM AS THIS COULD DAMAGE THE O-RING SEALS.
4. Mount the controller horizontally on the wall, near the reactor chamber. Ideally place the controller above the reactor and away from any water connection point, to prevent any water from potentially leaking onto the controller by means of a leak at a connection point or a 'sweating' system. Make sure you allow for a 'drip-loop' (Figure 1D) on the lamp, sensor and power cord (prevents water from potentially entering the controller). Affix the green ground wire to the grounding lug at the top of the reactor vessel and securely fasten with the lugnut provided (Figure 1E).
5. Install the UV lamp and sensor as outlined on pages 5-6.
6. When all plumbing connections are made, slowly turn on the water supply and check for leaks. The most likely cause for leaks is from the o-ring seal. In case of a leak, shut water off, drain cell, remove the retaining nut, wipe the o-ring and threads clean and re-install.
7. Once it is determined that there are no leaks, plug the system into the ground fault interrupter circuit, and check controller to ensure the system is operating properly. The controller is designed to detect both power to the system and lamp illumination. It is important to NEVER LOOK DIRECTLY AT THE GLOWING UV LAMP.
8. Allow the water to run for a few minutes to clear any air or dust that may be in the reactor.

**PLEASE NOTE:** When there is no flow, the water in the cell will become warm, as the UV lamp is always on. To remedy this, run a cold water tap anywhere in the house for a minute to flush out the warm water.

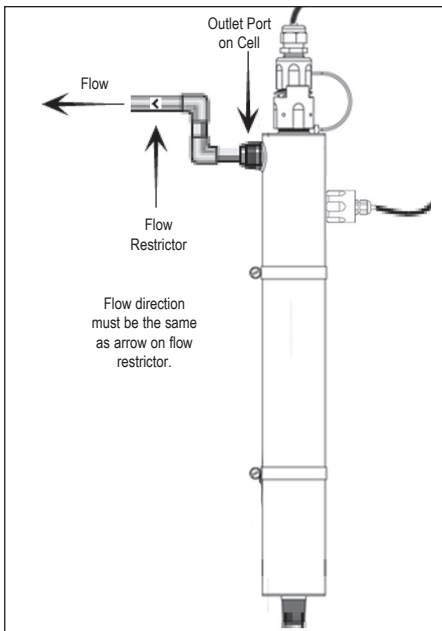

Figure 1C

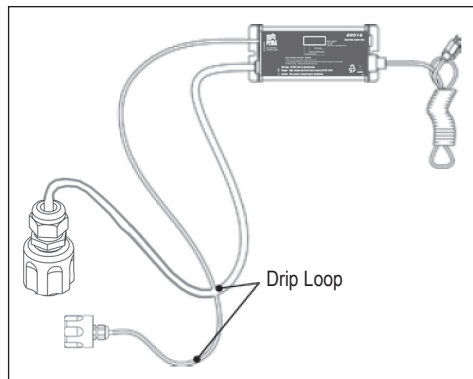

Figure 1D

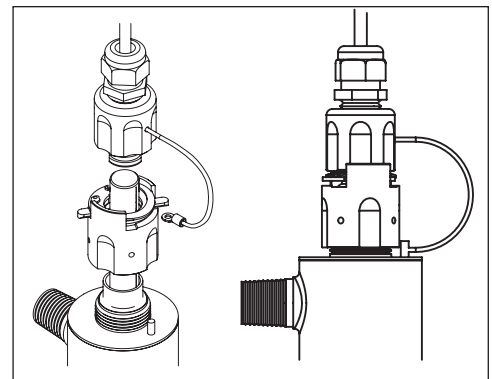

Figure 1E

## Disinfection Procedure

UV disinfection is a physical disinfection process and does not add any potentially harmful chemicals to the water. As UV does not provide a disinfection residual, it is imperative that the entire distribution system located after the UV be chemically disinfected to ensure that the water is free from any bacteriological contaminants. The disinfection process must be performed immediately after the UV unit is installed and repeated thereafter whenever the UV is shut down for service, without power, or inoperative for any reason. The procedure for sanitizing the plumbing system is readily accomplished as follows:

1. Shut off the upstream water supply that feeds water into the reactor chamber and depressurize water system. Remove the pre-filter cartridge and fill the sump with 1-2 cups of household (5.25%) bleach (chlorine) - Do NOT use hydrogen peroxide. At all times during the process, make sure the UV unit (and lamp) is turned on and operational!
2. Repressurize water system, open each faucet and allow cold water to run until you smell chlorine, shut the faucet off and then repeat the process for each faucet, including hot water. You must ensure that all taps, including outside faucets, dishwashers, shower heads, washing machines, connections to refrigerators, toilets, etc., pass chlorinated water.
3. Once all the locations have passed the chlorine disinfection solution, you will need to leave the solution sit for a period of 20 - 30 minutes. Reinstall the pre-filter cartridge into the filter and then flush the chlorine solution from the system until no chlorine smell is detectable. Make sure that each fixture that was disinfected in step 2 is completely flushed of the chlorine solution as the consumption of this water is not advised due to the extremely high concentration of chlorine. It is important to remember that in the event that a UV is briefly shut down for routine cleaning or during power interruptions where water could have passed through the system, the aforementioned procedure must also be followed.

**Note A:** The addition of chlorine (bleach) to a hot water tank that has in the past been fed with untreated raw water with high levels of other contaminants (iron, manganese, hydrogen sulphide, organics, etc.) will result in oxidation of these contaminants and may require repeated flushing of the hot water tank. This contingency must be dealt with independently under the startup procedure for any other conditioners that may form a part of the pre-treatment for the UV unit.

**Note B:** The above procedure (Steps 1 to 3) will result in a massive chlorine residual far in excess of the 0.5 to 1.0 mg/L typically present in municipally chlorinated water and of a magnitude consistent with the minimum 50 mg/L chlorine solution recommended for the disinfection of distribution systems known to be contaminated. Do not consume water until complete system has been flushed.

**PLEASE NOTE:** For UVSS-M models which include a 254nm UV intensity monitor, it should be noted that the introduction of the bleach solution required for disinfection WILL trigger a temporary low UV condition. This is due to the fact that the bleach physically 'clouds' the raw water. Once the bleach runs through the system, the alarm condition will return to normal. During this sanitization process, the audible alarm condition on the controller can be temporarily deferred by pressing the "RESET" switch for 5 seconds. By doing this, the audible alarm will be silenced and the solenoid relay will close (AC power will be provided to the normally closed (NC) solenoid, allowing water to pass through the system). The system will display [ *R2* ] on the controller LED. This condition will remain for 12 hours unless the system is manually reset as outlined on page 7 of this manual.

## OPERATION

- Always disconnect power before performing any work on the disinfection system.
- Regularly inspect your disinfection system to ensure that the power indicators are on and no alarms are present.
- Replace the UV lamp annually (or biannually if seasonal home use) to ensure maximum disinfection.
- Always drain the reactor chamber when closing a seasonal home or leaving the unit in an area subject to freezing temperatures.

# Operating & Maintenance Instructions

## CAUTION

Prior to performing any work on the disinfection system, always disconnect the power supply first.

## UV Lamp Replacement:

**NOTE: RESET LAMP LIFE TIMER AFTER LAMP REPLACEMENT** (Page 7). Refer to [www.lamprecycle.org](http://www.lamprecycle.org) for lamp disposal.

1. To replace the lamp, there is NO need to disconnect the system from the water supply, nor to drain the water from the reactor chamber DO NOT USE WATER DURING THIS PROCEDURE. Lamp replacement is a quick and simple procedure requiring no special tools. The UV lamp must be replaced after 9,000 hours of continuous operation (approximately one year) in order to ensure adequate disinfection.
2. Disconnect main power source and allow the unit to power down for 30 sec. Remove the lamp connector by rotating the tab of the gland nut (Figure 2A). Remove connector and lamp from the reactor chamber. Separate the lamp from the connector (Figure 2B). Do not twist the lamp from the connector, simply slide the two apart. Avoid touching the lamp on the glass portion. Handling the lamp at the ceramic ends is acceptable, however if you must touch the lamp glass, please use gloves or a soft cloth. Fully remove the lamp from the reactor chamber being careful not to angle the lamp as it is removed from the chamber. If the lamp is removed on an angle, pressure will be applied on the inside of the quartz sleeve, causing the sleeve to fracture.
3. To install a new lamp, first remove the lamp from its protective packaging, again being careful not to touch the lamp glass itself. Carefully insert the lamp into the reactor vessel (actually inside the quartz sleeve) (Figure 2C). Insert the lamp fully into the chamber leaving about two inches of the lamp protruding from the chamber. Next, attach the connector to the UV lamp (Figure 2B). Lamp is not keyed so it is important to ensure the lamp wires do not interfere with UV sensor detection as low UV alarms could result in UVSS-M models. The two wires should be oriented furthest away from the sensor port. Ensure the connector is fully seated onto the UV lamp (Figure 2D).
4. Once the lamp is fully seated on the connector, slide the connector over the gland nut. Once the connector is located fully over the gland nut, rotate the tab back in to lock the connector in place (Figure 2E).

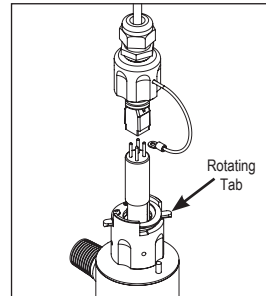

Figure 2A

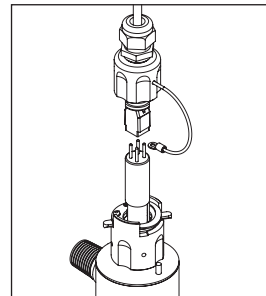

Figure 2B

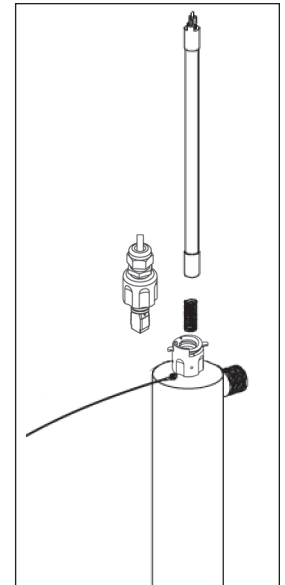

Figure 2C

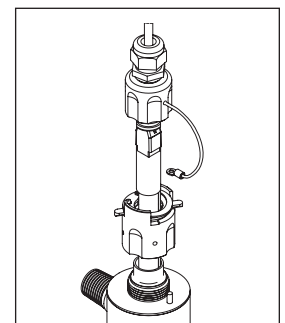

Figure 2D

## Quartz Sleeve Replacement / Cleaning:

Mineral deposits and sediment may accumulate on the quartz sleeve decreasing the UV energy detected. Good maintenance of filtration equipment will reduce the accumulation of residues. If necessary, remove the quartz sleeve and clean with a commercially available scale remover (CLR, Lime-Away, etc.) and a lint free cloth. Repeat the process as often as necessary to keep the quartz sleeve clean. Be sure to remove all traces of cleaning fluid from the sleeve before it is reinstalled in the reactor (be sure not to allow liquid inside the sleeve).

1. First remove the UV lamp by following steps 1 & 2 as outlined in the "Lamp Replacement" section on page 5.
2. Shut off the upstream water supply that feeds water into the reactor chamber.
3. Shut off the downstream water supply. If your system does not have a separate downstream valve, simply open a downstream faucet to release any pressure that may be built-up in the system.

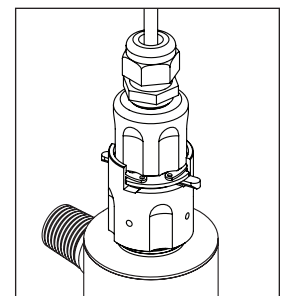

Figure 2E

4. Remove the gland nut by turning counter clockwise (Figure 3A). Place a small pail under the reactor chamber to catch any water that may leak from the system. Grasp the quartz sleeve and fully remove from the reactor chamber. As with the lamp, make sure the sleeve is removed from the reactor chamber being careful not to angle the sleeve as it is removed from the reactor (Figure 3B) to avoid breakage.
5. Clean the sleeve as outlined in above, or replace with a new sleeve. Reinstall the quartz sleeve in the reverse order. The UVSS reactor is designed for easy installation of the quartz sleeve by incorporating a unique sleeve centering guide. To install the sleeve, carefully insert the sleeve into the reactor chamber (do not drop) and push the sleeve until it firmly seats in the end of the reactor centered in the sleeve centering guides (Figure 3C). Install a lubricated (silicone release grease) o-ring (Part number 410866) onto the sleeve until it is positioned against the chamfered seat (Figure 3D).
6. Reinstall the gland nut on the reactor chamber and tighten by turning clockwise. The gland nut should be hand-tightened only, the use of a wrench is not required, nor recommended. Reinstall the connector as outlined in step four of the “Lamp Replacement” section.
7. Slowly turn on the water and pressurize the reactor to verify that there are no leaks.
8. Reconnect to power source and follow the Control box start-up sequence to make sure the system is operating properly.

**NOTE:** If the system is put on a temporary bypass or if it becomes contaminated after the disinfection system, it will be necessary to shock the system with household bleach for a full 20 minutes before resuming the use of the water.

### UV Sensor Replacement / Cleaning (UVSS-M Models Only):

**CAUTION:**

The UV sensor is a very delicate instrument. Extreme care is required when handling and cleaning. The sensor window itself is constructed from quartz which is extremely fragile, be careful you do not chip or break this quartz window. Manufacturer’s warranty does not cover damage due to neglect or misuse.

Mineral deposits and sediment may accumulate on the sensor window decreasing the UV energy detected. Good maintenance of the pre-treatment equipment will reduce the accumulation of residues. If the system indicates that the UV intensity is low, one cause may be a stained quartz sleeve and/or sensor window. To clean follow steps 1-3 below.

1. Before removing the sensor assembly, follow the steps as outlined in the “Quartz Sleeve Replacement And/Or Cleaning” section. The quartz sleeve should be cleaned at the same time as the UV sensor. Disconnect the UV sensor from the controller by disconnecting the sensor cable, turning the collar counter-clockwise (Figure 4B). To remove the sensor, grasp the body of the sensor and rotate counter-clockwise (Figure 4C) until the sensor is free of the threaded sensor port.
2. Once the sensor is free from the reactor chamber, clean the quartz window (Figure 4A) with a commercial scale remover (CLR or Lime-A-Way) and a lint free cotton swab (Figure 4D). Follow all manufacturer’s instructions regarding the cleaning fluid used. Do not use an abrasive cleaner on the sensor window. Scratching of the sensor window will void any manufacturer’s warranty on this item.
3. Ensure sensor lens is rinsed free of cleaning solution. Carefully re-assemble the sensor assembly with o-ring (Figure 4E) into the sensor boss. Screw the sensor into the boss and tighten to achieve a water-tight seal. DO NOT OVERTIGHTEN. Attach the sensor cable to the controller and return to service (Figure 4B).

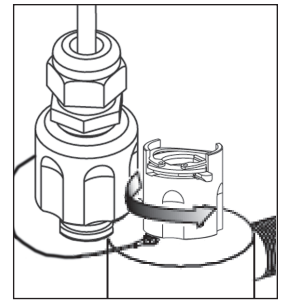

Figure 3A

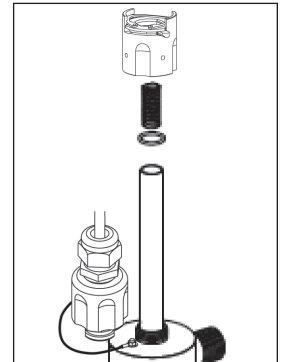

Figure 3B

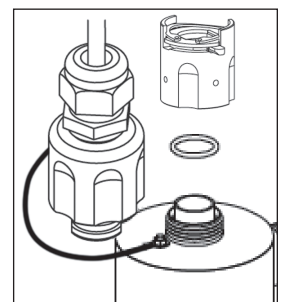

Figure 3C

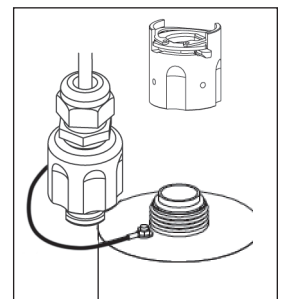

Figure 3D

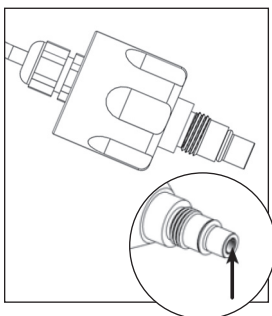

Figure 4A

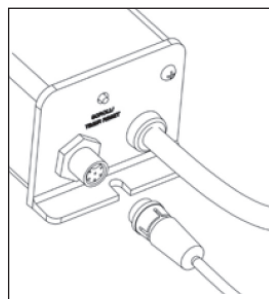

Figure 4B

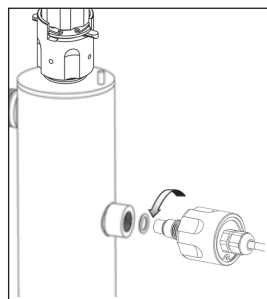

Figure 4C

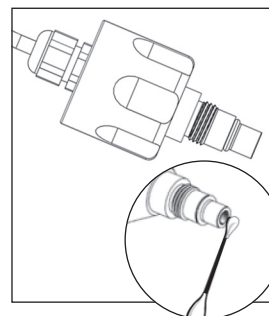

Figure 4D

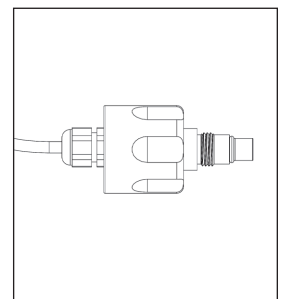
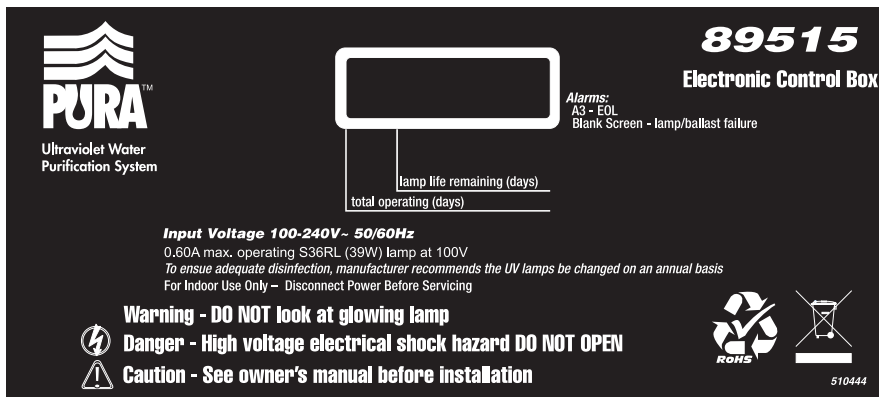

Figure 4E

## Electronic Control Box Operation – UVSS Models



### **365** 1. Lamp Life Remaining (days):

The controller tracks the number of days of operation of the lamp and the controller. The default screen will display the total lamp life remaining (in days). The controller will count down the number of days remaining until the lamp requires changing (365 days to 1 day). At "0" days, the controller will display [ *RR* ] on the display and supply an intermittent audible chirp (1 second on, 5 seconds off). indicating the need to change the lamp.

**DEFERRAL** - Once the "A3" or end of lamp life message is shown on the LED screen, the audible alarm can be deferred up to 4 separate times. The delay switch is designed to allow you time to address the alarm while you obtain a new UV lamp. This can be done by simply depressing the push-button "RESET" switch, which is located on the left side of the controller. Each time the reset switch is pressed the controller alarm is deferred seven days. Once the final 7 day deferral has been reached, the alarm can be silenced by changing the UV lamp and manually resetting the controller time. To do this, please follow the step by step instructions below:

#### **RESETTING LAMP LIFE:**

- Disconnect power supply from the controller.
- Remove expired lamp from the reactor chamber (refer to [www.lamprecycle.org](http://www.lamprecycle.org) for lamp disposal).
- Install new UV lamp and connect it to lamp connector (refer to page 5).
- Replace lamp connector.
- Hold down the "RESET" switch while reapplying power to the controller until you see "rSEt", then release.
- 5 second delay will occur until you hear an audible tone & LED display will read [ *365* ] once again.

Once you hear the tone, let go of the switch and the counter will be reset. Even though the alarm on the system can be deferred for a period of time, it is important to address each and every alarm condition as they are indicating that there is a potential problem with the system and should be remedied.

### **1680** 2. Total days of operation:

The controller also displays the total running time of the controller. To obtain this reading, press the push-button SWITCH once. The total running time of the controller will be numerically displayed in days. This information will remain displayed for ten seconds and will then revert back to lamp life remaining default screen. It should be noted that this value cannot be reset.

### **Blank Screen** 3. Lamp failure (blank screen):

When the system recognizes LAMP FAILURE (no current running through the lamp), the 4-segment display will be blank (no default LAMP LIFE REMAINING screen) and the system will supply an intermittent audible tone (1 second on, 1 second off). The system will remain in this state until the condition is remedied.



## Electronic Control Box Operation – UVSS-M Models

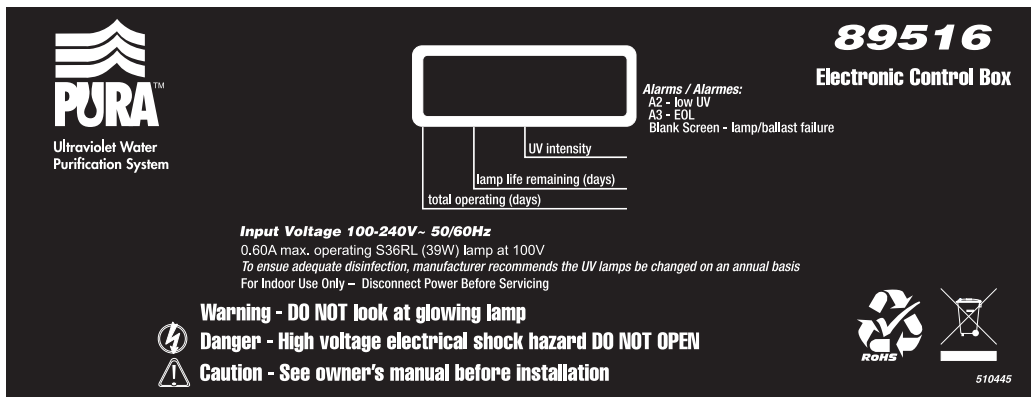

### **99** 1. UV Intensity (%) - UVSS-M Models Only:

The UVSS-M models incorporate a UV sensor which detects the discrete 254 nm wavelengths of the UV lamp. This information is relayed to the controller and is the default display shown in “% UV output”. The system will display the UV output between 50 to 99 percent. When the system drops below 50%, a low UV warning is displayed as [ R2 ] and alternately flashes (at 2 second intervals) back to the actual UV level.

Example: [ 49 ] Additionally, the system will supply an intermittent audible tone (2 seconds on, 2 seconds off), during low UV conditions.

**NOTE:** UV levels of:

- [ 65 ] to [ 99 ] Indicates the system is functioning within a normal operating range.
- [ 55 ] to [ 64 ] Indicates the UV level is still within a safe level, however cleaning or lamp replacement may soon be required.
- [ 50 ] to [ 55 ] Indicated the UV level is nearing the point of unsafe UV intensity, UV system should be immediately serviced.
- < [ 49 ] Indicates the UV level has now reached a level that is unsafe. At this level the water should not be consumed. The system/water supply should be examined to determine the reason for the low UV level of the UV intensity. At this level, the solenoid output has been activated and if a solenoid is installed, water will cease to flow.

**DEFERRAL** - To temporarily defer the audible alarm during a low UV alarm, press the push-button “RESET” switch and hold for five seconds. This will mute the audible alarm condition for 12 hours.

#### **CAUTION:**

This advanced warning system has been installed to provide you with the optimum protection against microbiological contamination of you water.

#### **DO NOT DISREGARD THE WARNING SIGNALS.**

The best way to ensure optimum UV performance is to have the water microbiologically tested by a recognized testing agency on a regular basis.

Possible causes for low UV alarm conditions:

- a) The UV lamp has perhaps reached a level whereby it can no longer adequately provide a sufficient level of disinfection due to age (> 9000 hours). The lamp should be replaced with a new lamp from the manufacturer of the same size and type.
- b) The quartz sleeve and/or the sensor window have become stained or dirty. Mineral deposits or sediment in the water that was not detected during the original water analysis may be the cause for this (refer to page 5-6 for cleaning instructions).
- c) Intermittent voltage drop in the household power supply reducing the lamp output. The lamp will return to normal when the power is restored to full voltage. **Note: the monitoring system will not operate during power failures.**
- d) The quality of the influent water has changed and is no longer within the acceptable operational range of the UV system. Perform a water analysis to determine the exact constituents and concentration levels.
- e) The UV sensor is not installed correctly (see page 6).

365

**2. Lamp life remaining:**

To obtain this reading, press the push-button SWITCH a single time and follow the steps as outlined on page 7, regarding the operation of this feature.

1680

**3. Total days of operation:**

To obtain this reading, press the push-button SWITCH two times in succession and follow steps as outlined on page 7, regarding the operation of this feature.

[Blank Box]

**4. Lamp failure (blank screen):**

Please refer to page 8 for explanation of this feature.

Note: On the UVSS-M systems, the audible tone provided for lamp failure is a continuous alarm, rather than the intermittent (1 second on, 1 second off) condition on the basic systems.

**5. Solenoid Output:**

Working in conjunction with the UV intensity monitor, the UVSS-M controller provides a powered, male IEC, solenoid (line outage) connection (note: this is NOT a dry contact). In addition, this solenoid connection is protected with a replaceable 2 amp isolated fuse. When the UV intensity monitor senses that the water is not adequately being treated and drops to 49% UV intensity or below, the internal relay is opened thereby stopping AC power flowing to the normally closed solenoid valve. The valve will remain closed (no power) until the UV level rises above 49%, at which time the solenoid will open, allowing for water to pass through. To temporarily defer the operation of this solenoid output for up to 12 hours, please refer to the instructions outlined on page 8 of this manual.

**NOTE: DURING BYPASS**, the water should NOT be consumed until the system has returned to a safe condition.

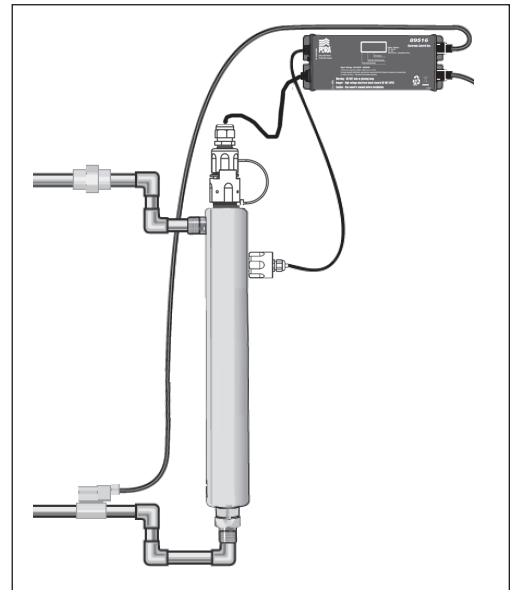

**Solenoid Installation**

**DISPLAY FAULT MODES**

LED display reads "A3"	<ul style="list-style-type: none"> <li>• lamp life expired - countdown is at "0" days</li> <li>• press reset button for a deferred alarm, replace UV lamp</li> </ul>
LED display is blank	<ul style="list-style-type: none"> <li>• controller is in lamp failure mode</li> <li>• power system down, allowing it to reset itself; apply power in order to confirm that the controller is able to power lamp</li> <li>• check to see if there is sufficient power to the UV system</li> </ul>
Low UV level displayed on screen	<ul style="list-style-type: none"> <li>• test water supply to see if water quality meets recommended parameter limits</li> <li>• clean quartz sleeve and sensor eye</li> </ul>
LED flashing "A2" and then back to UV level	<ul style="list-style-type: none"> <li>• low UV alarm deferral has been activated</li> <li>• UV level has dropped below 50% and the audible alarm has been muted by pressing the reset switch and holding it for 5 seconds</li> <li>• this audible alarm deferral will only last 12 hours</li> </ul>

# Troubleshooting

PROBLEM	CAUSE	CORRECTION
1. Pressure Drop	<p>A. Sediment pre-filter clogged</p> <p>B. Flow regulator</p>	<p>A. Replace filter cartridge with appropriate 5 micron cartridge. Note: check source water supply as fluctuations may occur in source pressure</p> <p>B. Flow regulator will result in pressure drop when approaching full flow.</p>
2. High Bacteria Counts	<p>A. Quartz sleeve is stained or dirty</p> <p>B. Change in feed water quality</p> <p>C. Contamination in water lines after UV system</p> <p>D. Possible break-through of sediment through pre-filter</p>	<p>A. Clean sleeve with scale cleaner and eliminate source of staining problem (ie. soften hard water, see page 5-6).</p> <p>B. Have source water tested to ensure that water quality is still within allowable limits for this system.</p> <p>C. It is imperative that effluent water stream be shocked with chlorine (bleach) before water leaves UV system - disinfection system must have a bacterial free distribution system to work effectively (see page 4).</p> <p>D. Have source water tested for turbidity - may need stepped filtration in order to catch all sediment entering water system (20 micron filter followed by UV system).</p>
3. Heated Product Water	A. Common problem caused by infrequent use of water	A. Run water until it returns to ambient temperature.
4. Water Appears Milky	A. Caused by air in the water lines	A. Run water until air is purged.
5. Unit Leaking Water	<p>A. Problem with o-ring seal (on gland nut and/or UV sensor)</p> <p>B. Condensation on reactor chamber caused by excessive humidity and cold water</p> <p>C. Inadequate inlet/outlet port connections</p>	<p>A. Ensure o-ring is in place, check for cuts or abrasions, clean o-ring, moisten with water/lubricant and re-install, replace if necessary.</p> <p>B. Check location of disinfection system and control humidity.</p> <p>C. Check thread connections, reseal with Teflon® tape and re-tighten.</p>
6. System Shutting Down Intermittently	A. Interrupted power supply	A. Ensure system has been installed on its own circuit, as other equipment may be drawing power away from UV (ie. pump or fridge). UV system should not be installed on a circuit which is incorporated into a light switch.
7. Lamp Failure Alarm On - New Lamp	<p>A. Loose connection between lamp and connector</p> <p>B. Moisture buildup in connector may keep lamp and connector from making a solid connection</p>	<p>A. Disconnect lamp from connector and reconnect, ensuring that a tight fit is accomplished.</p> <p>B. Eliminate chance of any moisture getting to the connector and/or lamp pins.</p>

# Parts Breakdown – UVSS-M Models (Monitored)

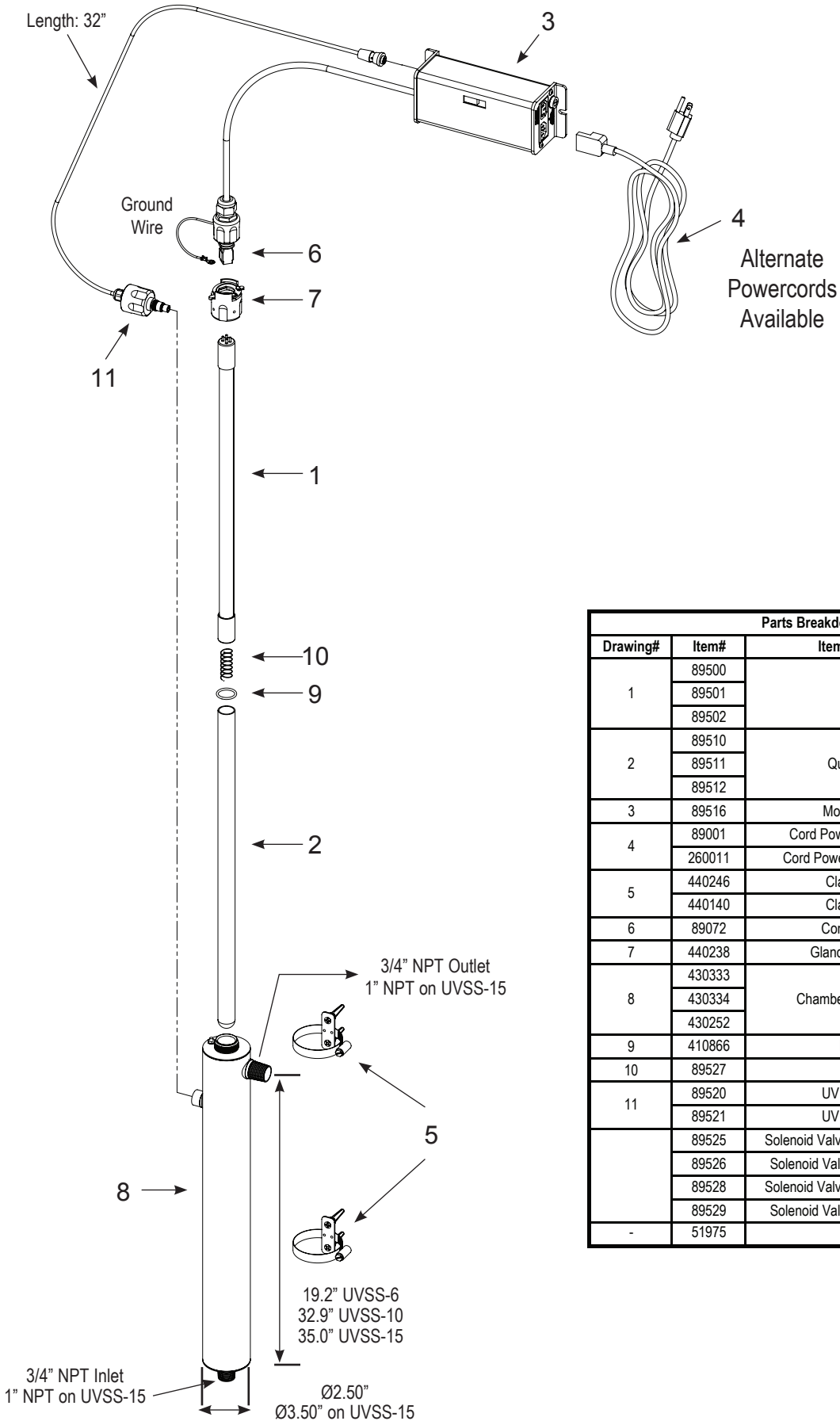

Parts Breakdown - UVSS-M Models			
Drawing#	Item#	Item Description	UV Models
1	89500	Lamp	UVSS-6M
	89501		UVSS-10M
	89502		UVSS-15M
2	89510	Quartz Sleeve	UVSS-6M
	89511		UVSS-10M
	89512		UVSS-15M
3	89516	Module, Control	All UVSS-M Models
4	89001	Cord Power, NA Plug, 120V	NA UVSS Models
	260011	Cord Power, Euro Plug, 230 V	EURO UVSS Models
5	440246	Clamp Kit, 2.5"	UVSS-6M, UVSS-10M
	440140	Clamp Kit, 3.5"	UVSS-15M
6	89072	Connector, 4 pin	All UVSS-M Models
7	440238	Gland Nut Assembly	All UVSS-M Models
	430333		UVSS-6M
	430334		UVSS-10M
	430252		UVSS-15M
9	410866	Kit, O-ring	All UVSS-M Models
10	89527	Spring	All UVSS-M Models
	89520	UV Sensor Assy	UVSS-6M, UVSS-10M
11	89521	UV Sensor Assy	UVSS-15M
	89525	Solenoid Valve (optional), 3/4", 120V	UVSS-6M, UVSS-10M
	89526	Solenoid Valve (optional), 1", 120V	UVSS-15M
	89528	Solenoid Valve (optional), 3/4", 230V	UVSS-6M, UVSS-10M
	89529	Solenoid Valve (optional), 1", 230V	UVSS-15M
-	51975	Manual	All UVSS-M Models

# Parts Breakdown – UVSS Models

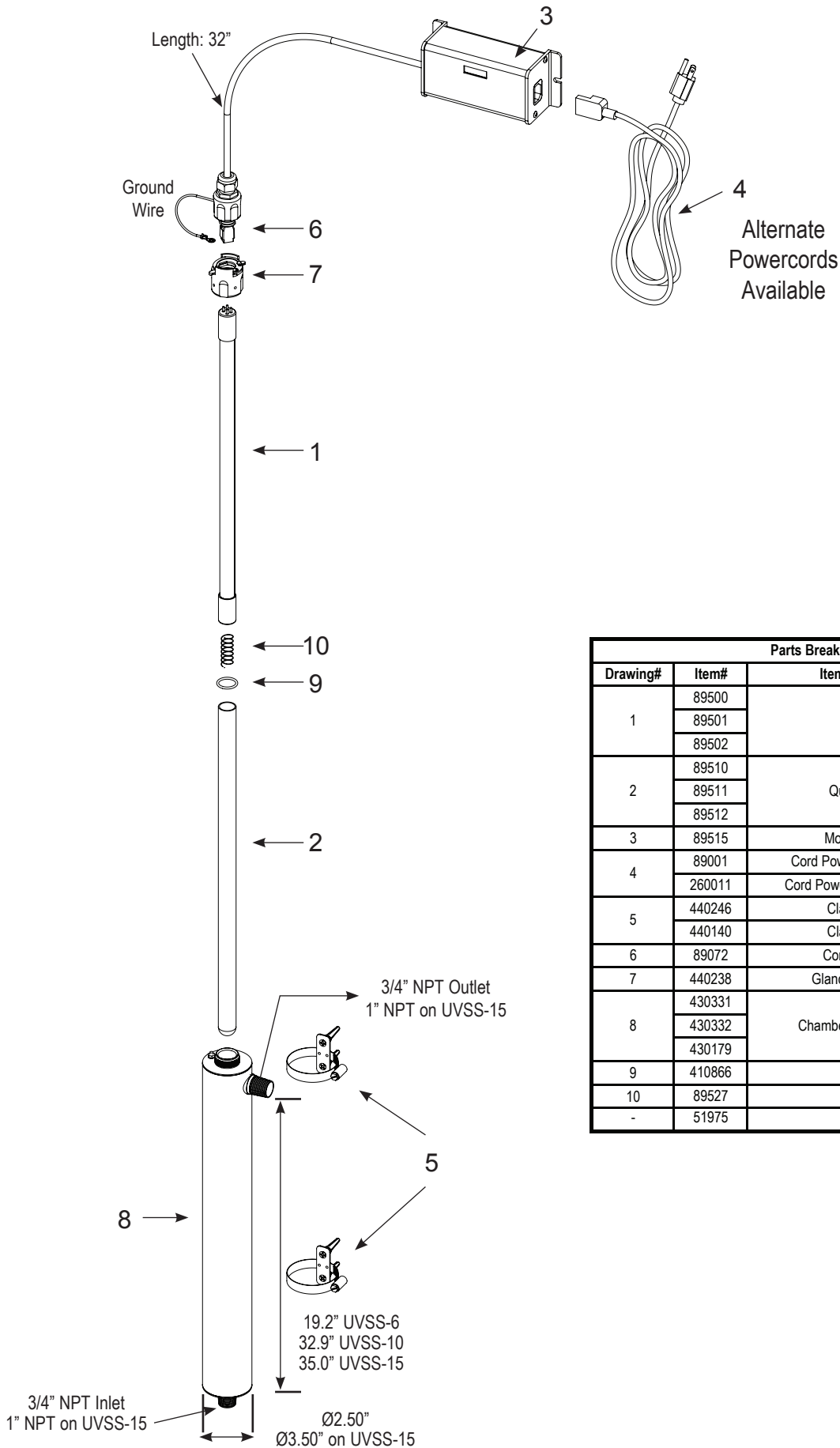

Parts Breakdown - UVSS Models			
Drawing#	Item#	Item Description	UV Models
1	89500	Lamp	UVSS-6
	89501		UVSS-10
	89502		UVSS-15
2	89510	Quartz Sleeve	UVSS-6
	89511		UVSS-10
	89512		UVSS-15
3	89515	Module, Control	All UVSS Models
4	89001	Cord Power, NA Plug, 120V	NA UVSS Models
	260011	Cord Power, Euro Plug, 230 V	EURO UVSS Models
5	440246	Clamp Kit, 2.5"	UVSS-6, UVSS-10
	440140	Clamp Kit, 3.5"	UVSS-15
6	89072	Connector, 4 pin	All UVSS Models
7	440238	Gland Nut Assembly	All UVSS Models
8	430331	Chamber, Stainless Steel	UVSS-6
	430332		UVSS-10
	430179		UVSS-15
9	410866	Kit, O-ring	All UVSS Models
10	89527	Spring	All UVSS Models
-	51975	Manual	All UVSS Models

# **PURA® Stainless Steel Ultraviolet Water Purification Systems LIMITED WARRANTY**

Subject to the conditions and limitations described below, the manufacturer warrants its stainless steel ultraviolet drinking water systems ("Product") when installed in accordance with PURA® specifications, to be free from defects in materials and workmanship under normal use within the operating specifications given in page 2 of this manual for the following periods; Ultraviolet lamps and sensor probes to be free from defects in material and workmanship for a period of one (1) year, reactor chamber for a period of seven (7) years and all remaining parts of the Product including the control for a period of two (2) years from the date of purchase with receipt as proof of purchase. This warranty shall apply only to the original end-user of the Product.

If the Product or any warranted component is found defective, the manufacturer, at its sole option, will repair or replace such Product or warranted component, or will refund all or a pro-rated portion of the Product's purchase price. You pay only freight for repaired or replaced parts from our factory and local dealer charges, including but not limited to labor charges, travel and transportation expenses, and handling fees.

This warranty shall not apply to any part damaged by accident, fire, flood, freezing, Act of God, bacterial attack, filter fouling and/or scaling, sediment, misapplication, neglect, alteration, installation, or operation contrary to our printed instructions, or by use of accessories or components which do not meet PURA specifications. If the drinking water system is modified by anyone other than an authorized PURA dealer, the warranty shall be void.

ALL IMPLIED WARRANTIES, INCLUDING WITHOUT LIMITATION WARRANTIES OF MERCHANTABILITY AND FITNESS FOR PARTICULAR PURPOSE, ARE LIMITED IN DURATION TO THE PERIOD SPECIFIED ABOVE FOR PRODUCT AND COMPONENTS DESCRIBED IN THIS LIMITED WARRANTY.

As a manufacturer, we do not know the characteristics of your water supply. The quality of water supplies may vary seasonally or over a period of time. Your water usage may vary as well. Water characteristics can also change if the Product is moved to a new location. For these reasons, we assume no liability for the determination of the proper equipment necessary to meet your requirements, and we do not authorize others to assume such obligations for us. Further, we assume no liability and extend no warranties, expressed or implied, for the use of this product with a water source that does not meet the Conditions For Use in the Installation Guide & Owner's Manual.

THE MANUFACTURER'S OBLIGATIONS UNDER THIS WARRANTY ARE LIMITED TO THE REPAIR OR REPLACEMENT OF THE FAILED PRODUCT OR COMPONENTS OR THE REFUND OF THE PURCHASE PRICE (AT WATERGROUP'S OPTION), AND WE ASSUME NO LIABILITY WHATSOEVER FOR DIRECT, INDIRECT, INCIDENTAL, CONSEQUENTIAL, SPECIAL, GENERAL, OR OTHER DAMAGES, WHETHER FROM CORROSION OR OTHER CAUSES.

Some states do not allow limitations on how long an implied warranty lasts, so the above limitation may not apply to you. Similarly, some states do not allow exclusion of incidental or consequential damages, so the above limitations or exclusions may not apply to you. This warranty gives you specific legal rights, and you may also have other rights, which vary from state to state. Consult your authorized PURA Dealer for warranty and service information.

For parts or service, contact:



**WATERGROUP INC.**    **WATERGROUP COMPANIES INC.**  
FRIDLEY, MN            REGINA, SK • CAMBRIDGE, ON  
1-800-354-7867        1-877-288-9888  
[www.watergroup.com](http://www.watergroup.com)